

Control System Design

Risk Assessment

Using Fuzzy Logic

VPI - AOE - 239

Dr. Mark R. Anderson
Associate Professor

Department of Aerospace and Ocean Engineering
Virginia Polytechnic Institute and State University

October 1996

Foreword

The research and development reported here was accomplished for the Dynamics and Control Branch of NASA Langley Research Center under grant NAG-1-1573. The NASA project engineer was Mr. Martin R. Waszak. The principal investigators were Dr. Mark R. Anderson and Dr. William H. Mason. Graduate students involved in the work included Mr. Valery Razgonyaev, Mr. Alexander Suchkov, and Ms. Chunhong Zhang. The research was performed during the period from January 1994 to January 1997.

The views and conclusions contained herein are those of the author and should not be interpreted as necessarily representing the official policies or endorsements, either expressed or implied, of NASA Langley Research Center or any other agency of the U.S. Government.

Table of Contents



Introduction.....	1
Short-Period Approximation.....	2
Regions in the Complex Plane.....	4
Design Requirements.....	9
Control System Design Strategies.....	13
Fuzzy Logic Rules.....	17
Examples.....	35
Suggested References.....	41

Introduction

This manual describes a technique that can be used to assess the impact of the flight control system on aircraft configuration geometry. The primary purpose is to perform trade-off studies between different aircraft configurations in the preliminary design phases of development. It can also be easily automated and adapted for use in aircraft configuration optimization problems.

The underlying approach is to determine the control system structure that is needed to correct deficiencies in the dynamics of the aircraft. The complexity of the control system is assumed to measure the amount of risk associated with that aircraft (if it were built). Configurations that require a very simple control system architecture would incur only a small risk. Configurations with a very complicated control system would be assigned a higher risk.

The required control system architecture is determined using a set of fuzzy logic rules. These rules are developed using experience and knowledge about how control systems are designed. Using this approach, a control system is not actually designed for a given configuration under study. Only the required control system structure is determined. The final design of the control system would come after the final configuration has been selected and detailed aerodynamic and structural models are developed.

This report describes a procedure and rulebase to determine the flight control design risk for the longitudinal axis of aircraft motion. Only one specification regarding aircraft flying qualities is considered. However, the rules and methods described in this report could also be expanded to include other design requirements and specifications.

Short-Period Approximation

The airplane will be modeled using the longitudinal, short-period approximation. This approximation assumes that the aircraft is flying at constant altitude and speed. It is also based upon small angle assumptions and, therefore, cannot be used for rapid or highly dynamic flight trajectories. The equations describing the short-period motion of a typical airplane are given by,

$$\dot{\alpha} = Z + q$$

$$\dot{q} = M + M_q q + M_{\delta_e} \delta_e$$

$$a_z = V(\dot{\alpha} - q)$$

where α is angle-of-attack, q is body-axis pitch rate, a_z is vertical acceleration, and δ_e is elevator deflection.

The parameters Z , M , M_q , and M_{δ_e} are dimensional stability derivatives. The dimensional derivatives can be estimated using information about the aircraft geometry and aerodynamics. Equations for the dimensional derivatives are,

$$Z = -\frac{\bar{q} S C_L}{m V}$$

$$M = \frac{\bar{q} S c C_m}{I_{yy}}$$

$$M_q = \frac{\bar{q} S c^2 C_{mq}}{2 I_{yy} V}$$

$$M_{\delta_e} = \frac{\bar{q} S c C_{m \delta_e}}{I_{yy}}$$

where \bar{q} is dynamic pressure, c is chord length, S is wing reference area, m is mass, I_{yy} is a moment of inertia, and V is velocity. The terms C_L , C_m , C_{mq} , and $C_{m \delta_e}$ are non-dimensional aerodynamic derivatives. They must be estimated for each aircraft configuration under study along with the geometric and weight variables (S , c , m , and I_{yy}).

By taking the Laplace transform of the equations above, the following transfer functions can be obtained,

$$\frac{\delta_e(s)}{e(s)} = \frac{M_{\delta_e}}{s^2 + 2bs + c}$$

$$\frac{q(s)}{e(s)} = \frac{M_e (s+a)}{s^2 + 2bs + c}$$

$$\frac{a_z(s)}{e(s)} = -\frac{aVM_e}{s^2 + 2bs + c}$$

The coefficients of the transfer function polynomials are,

$$a = -Z$$

$$b = -\frac{Z + M_q}{2}$$

$$c = Z M_q - M$$

These coefficients (a,b,c) will be used as input values into the control system risk assessment program. It is assumed the user will be able to estimate the non-dimensional aerodynamic derivatives and aircraft geometry variables for each configuration under study.

Regions in the Complex Plane

In order to determine the control system that is required for a given configuration, the characteristic roots of the bare-airframe must be analyzed. This analysis consists of determining the region in the complex plane where the roots are located. With this information, one can then determine what control system architecture that is needed to move the roots into the region specified by the design requirements.

From the transfer functions listed previously, one finds the characteristic equation for the aircraft is given by the second-order polynomial,

$$s^2 + 2bs + c = 0$$

The characteristic roots are the values of the Laplace variable s which satisfy the characteristic equation. Therefore, these roots are given by solutions to the quadratic equation above, or

$$s = -b \pm \sqrt{b^2 - c}$$

The first situation to consider is to determine whether the characteristic roots are complex or real. In the complex case, the discriminant is negative, i.e.

$$b^2 - c < 0$$

Therefore, a test for complex roots can be completed using coefficients of the characteristic equation and the expression above. Namely, if $b^2 - c < 0$ then the roots are complex and if $b^2 - c > 0$ then the roots are real

Two membership functions can be constructed to perform this test. One membership function indicates the presence of complex roots while the other indicates the case of real roots. These membership functions are shown in Figure 1.

Membership functions are used to determine whether a particular input or output value belongs to, or is a member of, a given set. For the case depicted in Figure 1, all values of b and c leading to the result $b^2 - c < 1$ belong in the "complex" set while all values of that lead to $b^2 - c > 1$ belong to the "real" set. The utility of fuzzy logic becomes apparent when one considers the case when $b^2 - c = 1$. According to Figure 1, $b^2 - c = 1$ belongs to both the "complex" and the "real" set. However, the membership functions also reveal $b^2 - c$ has membership of only 50% (0.5) in each of these sets. Thus, a "fuzzy" (rather than crisp) transition occurs as values pass from one set into another.

In this work, the equations used to represent the fuzzy logic membership functions are called sigmoid functions. These functions have the form,

$$f(x) = \frac{1}{1 + e^{-(x -)}}$$

where α is the curvature and β is the center of the function. The "complex" set in Figure 1 is represented by a sigmoid function with $\alpha = -10$, $\beta = 0$. The "real" set is represented by $\alpha = 10$, $\beta = 0$.

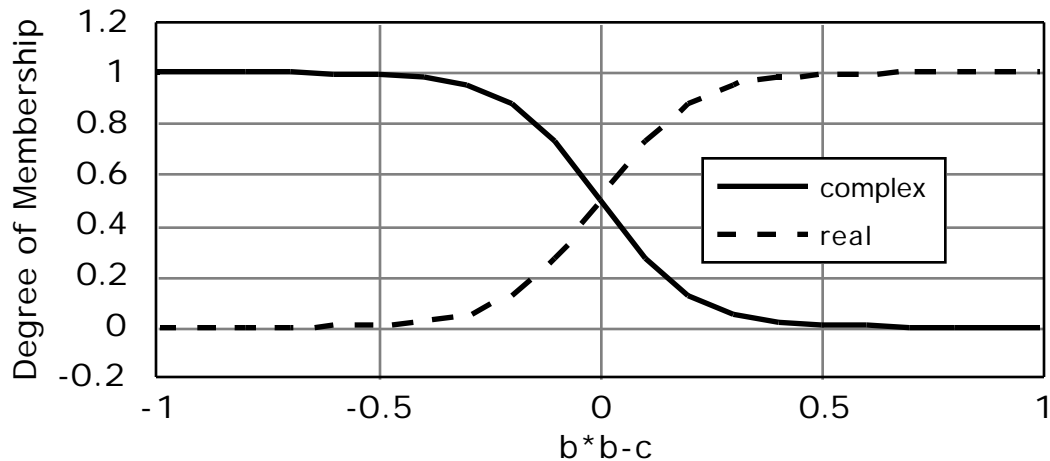

Figure 1 Short-Period Pole Discriminant Membership Functions

We will also need to know if the roots are stable or not. Stable roots have their real part in the negative left-half-complex-plane. This test is easily performed use Routh's stability criterion. The Routh stability test involves the signs of the characteristic equation coefficients. If all of the coefficients are positive, the roots will be stable. If the coefficients change sign, the number of sign changes will indicate the number of right-half-plane (unstable) characteristic roots.

For the second-order case, we only need to consider the signs of the coefficients b and c . However, keep in mind that the sign of the highest order coefficient (i.e. s^2) dictates the start of the sequence. In this case, the sign of the s^2 term is positive. There are four possibilities for the signs of b and c . When both b and c are positive, there are no unstable roots. If the signs alternate with $b < 0$ and $c > 0$, then both roots will be unstable. Finally, only one unstable root will result if either $b > 0$ and $c < 0$ or $b < 0$ and $c < 0$.

Note that when $c > 0$, either both roots are stable or unstable. Thus, both roots are together in either the left-half-plane or right-half-plane when $c > 0$. When $c < 0$, we have one stable root and one unstable root. As a result, the roots are separated into the left-half-plane and right-half-plane when $c < 0$. We will therefore create a membership function based upon the sign of c to indicate whether the roots are together or separate. This membership function is shown in Figure 2.

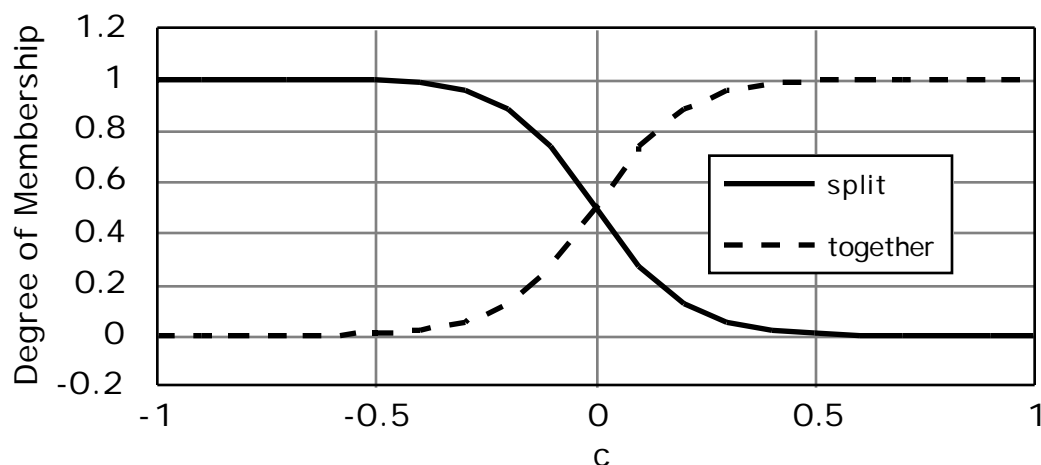

Figure 2 Short-Period Pole Grouping Membership Functions

The sign of the coefficient b is closely related to system stability. With complex roots, $b > 0$ indicates stable roots and $b < 0$ indicates unstable roots. This is not a general statement on stability; however, as we have already noted that it is possible to have one unstable root even though $b > 0$. Nevertheless, the sign of the coefficient b will be used to represent stability. Positive values of b will indicate stable aircraft and negative values will indicate unstable aircraft roots. A membership function describing this relationship is shown in Figure 3.

When the roots are real, we will need to know their location relative to the short period zero of the pitch rate transfer function. This transfer function has one zero located on the real axis at $s = -a$. Since a is always positive, this zero is always negative and we know that it will lie to the left of the characteristic roots when they are both unstable. The other possibilities are that the zero lies between the two real roots or to the right of the roots. Each case can be distinguished by the location of the zero to the nearest characteristic root. In terms of the characteristic equation coefficients, the two real roots are given by,

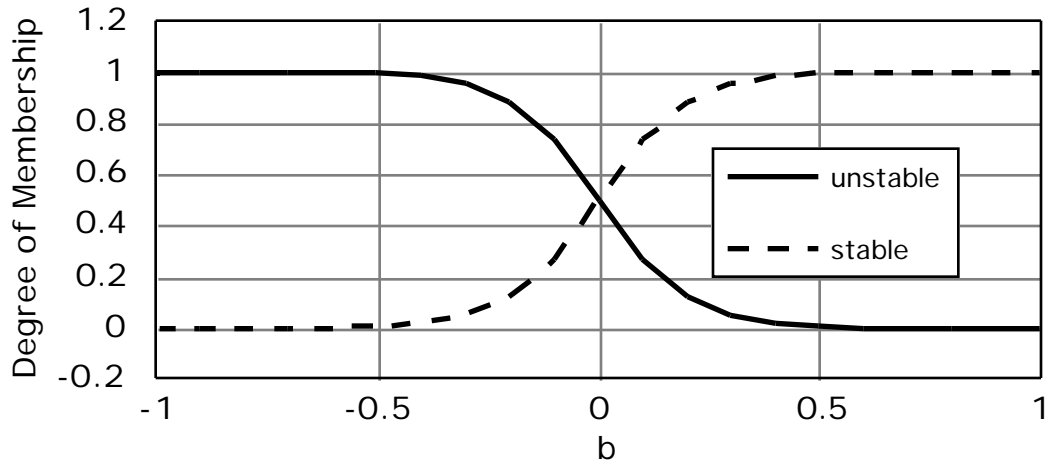

Figure 3 Short-Period Pole Stability Membership Functions

$$s_1 = -b + \sqrt{b^2 - c}$$

$$s_2 = -b - \sqrt{b^2 - c}$$

The zero will lie to the left of the characteristic roots if $-a < s_2$, or,

$$-a < -b - \sqrt{b^2 - c}$$

or,

$$b - a < -\sqrt{b^2 - c}$$

In the opposite case, the zero lies to the right of the roots if $-a > s_1$, or,

$$-a > -b + \sqrt{b^2 - c}$$

or,

$$b - a > \sqrt{b^2 - c}$$

From these two expressions, we can see that the zero lies between the two characteristic roots if,

$$-\sqrt{b^2 - c} < b - a < \sqrt{b^2 - c}$$

Membership functions can be constructed to indicate the relative location of the pitch rate transfer function zero and the short-period characteristic roots. By dividing the expression above by $\sqrt{|b^2-c|}$, the following inequality results,

$$-1 < d < +1$$

where,

$$d = \frac{b - a}{\sqrt{|b^2-c|}}$$

Note that an absolute value is used to compute the parameter d. The absolute value is used to insure that d is a real number even when the characteristic roots are complex. The parameter d then indicates the relative zero location. When $d > 1$, the zero is to the right of the roots and, when $d < -1$, the zero is to the left of the roots. When d lies between -1 and +1, the zero lies between the two characteristic roots. A membership function to represent this relationship is shown in Figure 4.

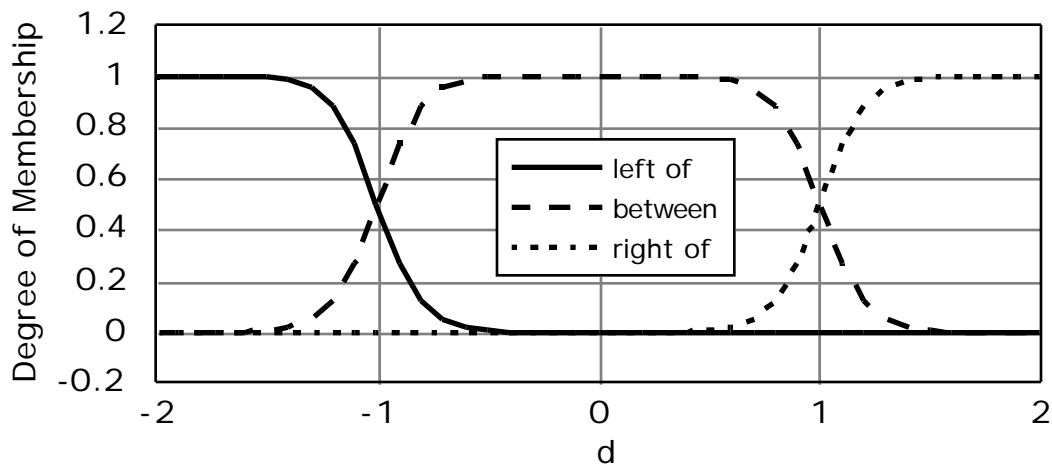

Figure 4 Short-Period Zero Location Membership Functions

Design Requirements

Flight control systems are designed with several requirements in mind. Disturbance rejection, stability, command tracking, and ride comfort are some of the requirements that might be considered in the design. However, many of these requirements only come into play when a detailed design is being considered. Usually a very high fidelity model of the aircraft is needed to determine if these requirements are met or to implement a control system if the requirements are not met.

Aircraft flying qualities are perhaps the most important requirements to be considered in the conceptual design stage. These requirements are determined by the rigid-body dynamics of the aircraft and usually determine the basic structure of the control system that is required for the airplane. Certainly many final control system designs far exceed the complexity of that needed to meet flying qualities requirements, but the flying qualities requirements usually provide the foundation for the start of the design.

For this report, only one flying qualities specification will be considered for the longitudinal axis. This specification defines desired regions in the complex plane in which the characteristic roots must lie. This specification form is particularly amenable to the fuzzy logic algorithm because the desired regions can be expressed using membership functions.

The flying qualities specification considered herein is called the " ζ_{sp} and ω_{sp} " specification in MIL-STD-1797 (Flying Qualities of Piloted Aircraft, 28 June 1995). This specification involves the short-period natural frequency (ω_{sp}), damping ratio (ζ_{sp}), and pitch rate numerator time constant (τ_p). In terms of the transfer function coefficients defined previously, we have,

$$\zeta_{sp} = \frac{1}{a}$$

$$\omega_{sp} = \frac{b}{\sqrt{|c|}}$$

$$\tau_p = \sqrt{|c|}$$

Table 1 shows the " ζ_{sp} and ω_{sp} " specification for three different flight categories. Category A is for precision flying such as air-to-air refueling. Category B is for cruising flight and Category C is for take-off and landing. The limits listed in Table 1 represent the Level 1 (satisfactory) regions for each flight category.

The specifications listed in Table 1 are the minimum level requirements that must be met. They are not necessarily the requirements that the flight control engineer would design toward. In other words, the design objective might be to exceed the minimum requirements by some extent. Also shown in Table 1 is a "Design" entry. This row represents the design goals which one might attempt to

achieve in order to exceed the minimum specification requirements for all flight categories.

Table 1 MIL-STD-1797 Short Term Pitch Flying Qualities Specification

Category	σ_{sp}^2 min	σ_{sp} min	σ_{sp} max	σ_{sp} min	$1/\sigma_{sp}^2$ min
A	1.5	0.35	1.3	1.0	-
B	1.0	0.30	2.0	-	-
C (Class I, II-C, IV)	1.2	0.35	1.2	0.87	0.38
C (Class II-L, III)	1.2	0.35	1.2	0.70	0.28
Design	1.5	0.35	1.2	1.0	0.38

At first glance one might conclude that designing to exceed the minimum requirements might lead to unnecessarily conservative designs. However, recall that the purpose here is to evaluate control system design risk assessment at the preliminary design stage. Consequently, only an approximate representation of the design requirements are needed.

Figure 5 shows the design goals plotted with respect to the aircraft short period natural frequency and zero. Note that the design region is bounded by all three requirements of these two parameters. In order to simplify the requirements slightly (this eliminates one set of membership functions), the design goal for the product of σ_{sp}^2 will be shifted upward. The shifted requirement is,

$$(\sigma_{sp} - 0.43)^2 > 1.5$$

This shifting eliminates the requirement for $\sigma_{sp} > 1.0$ rad/s because now all of the configurations that meet the shifted σ_{sp}^2 requirement will also meet the σ_{sp} requirement.

The short-period flying qualities design requirement can then be normalized and written in the following forms,

$$e > 1 \quad \text{where } e = \frac{1}{0.38^2}$$

$$0 < f < 1 \quad \text{where } f = \frac{\sigma_{sp} - 0.35}{0.85}$$

$$g > 1 \quad \text{where } g = \frac{(\sigma_{sp} - 0.43)^2}{1.5}$$

Simple membership functions can be written for each of these design goals. They are shown in Figures 6 through 8. When the requirement is met, the membership function is labeled "within" and, otherwise, the function is labeled "below" or "above" the requirement.

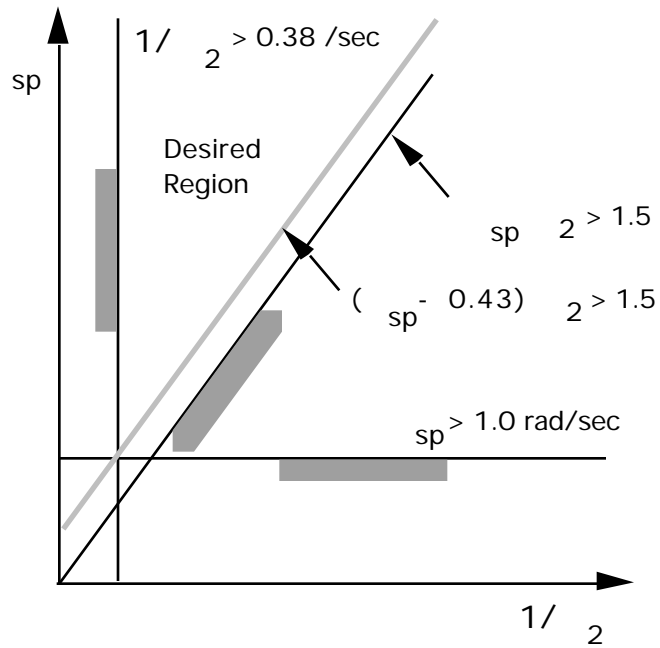

Figure 5 Short Period Design Goals

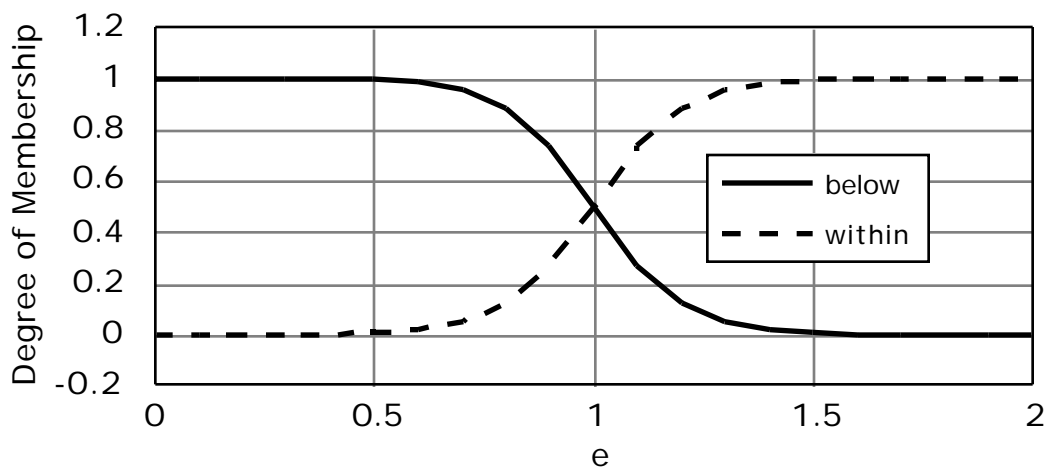

Figure 6 Short-Period Zero Requirement Membership Functions

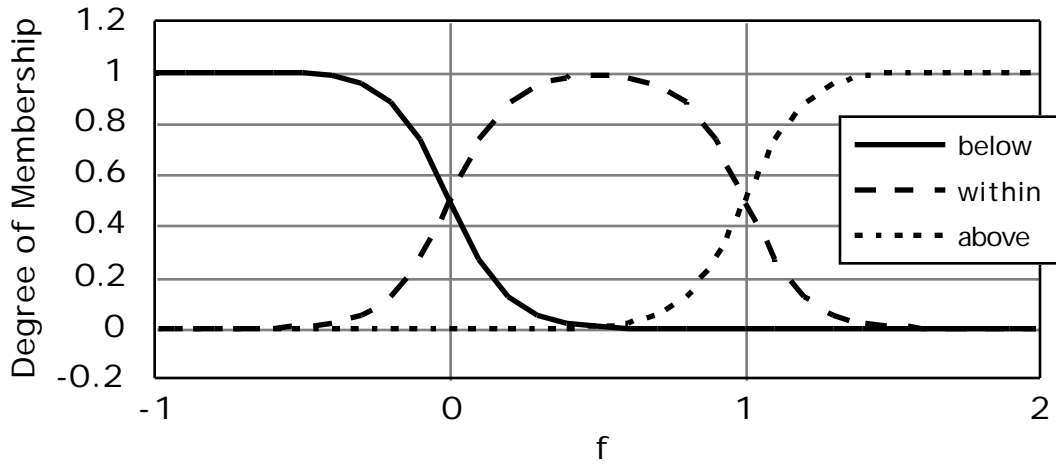

Figure 7 Short-Period Damping Requirement Membership Functions

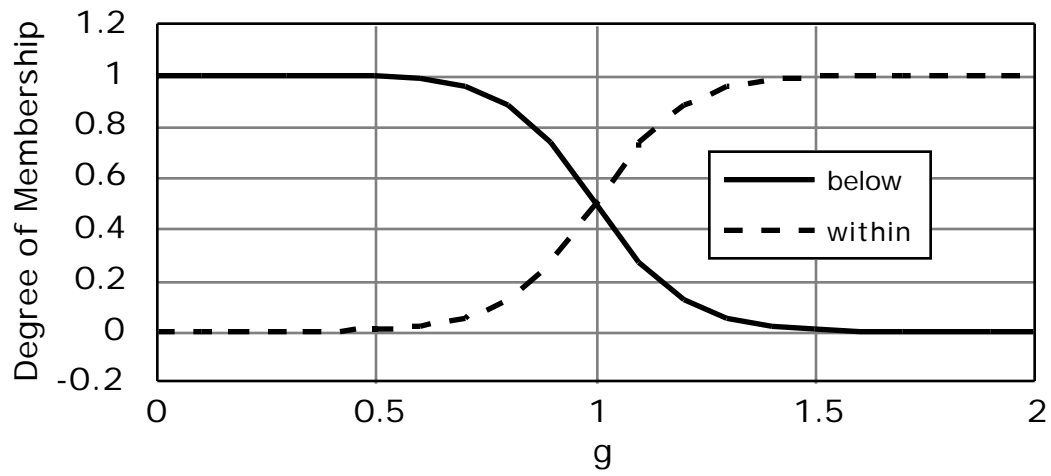

Figure 8 Short-Period Natural Frequency Requirement Membership Functions

Control System Design Strategies

There are six basic flight control system architectures that are used to control the longitudinal, short-period mode of a conventional aircraft. The control system architecture that is needed for a given aircraft will depend on the dynamic properties of the aircraft as well as the design requirements. These issues have been addressed in previous sections of this report, resulting in a description of membership functions that categorize both the properties of the aircraft and the design requirements.

The simplest possible control structure includes no feedback signals at all. No control system is required when the aircraft meets the design requirements without alteration. In this case, the aircraft can be flown satisfactorily without any stability augmentation whatsoever. It is evident that very little flight control risk is encountered in this configuration so we will associate "low" risk with the case when no feedback control is needed.

Probably the simplest stability augmentation scheme for the longitudinal axis is the pitch-rate-damper. This control system architecture assumes that the pitch rate gyro is used to measure aircraft body-axis pitch rate. These sensors are relatively inexpensive and have been used for many years in the aircraft industry. However, although a pitch damper is not particularly sophisticated control system, it does incur more risk than no control at all. Consequently, we will associate "medium" risk with a pitch damper design.

When designing a pitch damper, a simple gain is applied to the measure pitch rate and the product is added to the elevator command signal. The characteristic equation for the pitch damper controlled aircraft becomes,

$$1 + K_q \frac{M_e (s+a)}{s^2 + 2bs + c} = 0$$

Now consider the effect of the pitch damper gain K_q . When K_q is zero, the characteristic roots are given by the solution of $s^2 + 2bs + c = 0$. This situation was discussed previously for the open-loop airplane.

When $K_q > 0$, the root locus branches will migrate towards the pitch rate transfer function zero located at $s = -a$. Since a is positive always, the tendency is that the characteristic roots will increase damping as K_q is increased. As a result, the pitch damper is used primarily in the case when insufficient short-period damping occurs.

An accelerometer measures translational acceleration of the airplane. These devices are also relatively inexpensive. An acceleration feedback signal structure is also about as mature a technology as the pitch damper. Probably the only difference between the pitch rate and acceleration feedback is that the acceleration feedback gain is more dependent on flight condition. This dependency means that the accelerometer signal control system will involve more gain scheduling than the pitch damper. However, these are not insurmountable problems by any modern

means, so a "medium" control risk will also be associated with the accelerometer feedback.

The characteristic equation resulting from accelerometer feedback is,

$$1 - K_{az} \frac{aVM_e}{s^2 + 2bs + c} = 0$$

Since the vertical acceleration transfer function has no zeros, the characteristic roots will converge towards Butterworth patterns as K_{az} is increased. The Butterworth pattern extends the root locus branches into the left-half-plane at constant angles that are symmetric about the real axis. Thus, the accelerometer signal feedback tends to increase natural frequency (or the distance from the roots to the origin of the complex plane).

It is also possible to use both pitch rate and acceleration feedback signals. In this case, the characteristic equation becomes,

$$1 + K_q \frac{M_e (s + (1 - K_q V / K_{az})a)}{s^2 + 2bs + c} = 0$$

From this expression, we see that the closed-loop characteristic root loci will behave in a pattern similar to the pitch damper as K_q is increased. However, the zero of attraction is now at $s = - (1 - K_q V / K_{az})a$ rather than $s = -a$ in the pitch damper case. With the blended feedback signal arrangement, the control system has the ability to place this zero in a location such that the root locus branches behave as required. The blended arrangement is therefore very useful in correcting airplanes that are deficient in both short-period damping and natural frequency.

It is worth noting at this time that the blended acceleration/pitch rate feedback control architecture does not change the zero location of the pitch rate transfer function. The blended feedback signals change the location of the "blended" zero which is neither the pitch rate or acceleration transfer function zero. Therefore, while this structure helps to improve short-period damping and natural frequency, it cannot be used to meet requirements on the pitch rate zero itself (i.e. 1/ 2).

Because the blended signal feedback requires at least two sensors and two control system gains that are probably scheduled with flight condition, we will associate at "high" control design risk with airplanes that need this control system architecture.

The last control system configuration that will be considered is the proportional+integral control system. This system uses only a pitch rate sensor. The measure pitch rate is passed through a filter that includes a proportional gain and an integrator. The resulting filtered signal is then sent to the elevator to be summed with the pilot's input. The characteristic equation that results is,

$$1 + \frac{(K_q s + K_I) M_e (s+a)}{s[s^2 + 2bs + c]} = 0$$

One can see from the characteristic equation above that the control system designer can now choose the location of the attracting zero arbitrarily. Also, an additional pole exists that is located at the origin in the complex plane.

The proportional+integral controller architecture is very powerful design tool in that it can be used to stabilize aircraft with real unstable roots. Most statically unstable aircraft, or aircraft with aft center-of-gravity positions, need a control system of this type.

Since the proportional+integral control system actually has dynamic elements in the control computer, it should be considered "very high" design risk. While it is indeed a powerful design tool, there are many practical design issues that must be addressed with this type of control system. For example, the integrator element of the controller must be limited so that it does not "wind-up" when the control surfaces reach their physical limits.

The last control system feature that is common in longitudinal axis designs is a trailing or leading edge flap schedule or augmentation controller. Because we may have requirements on the location of the pitch rate zero $a = 1/\tau$, some kind of control system may be required to change the location of this zero. As mentioned previously, this zero is computed from,

$$a = -Z = \frac{qSC_L}{mV}$$

From this expression, we see that the pitch rate zero depends upon the lift curve slope of the aircraft C_L . The most direct means of changing the lift curve slope is to change the flap settings on the aircraft. Sometimes a flap schedule is used while other times a feedback loop consisting of angle-of-attack feedback to the flaps is used. The flap schedule can be complicated because it may be scheduled as a function of dynamic pressure, airspeed, or altitude. For a feedback augmentation scheme, a reliable angle-of-attack measurement is needed. Regardless of the mechanization, the system usually requires accurate air data measurements. Therefore, we will consider a flap augmentation scheme a "very high" control design risk.

Table 2 summarizes the application and risk associated with each of the six control system architectures. This information can be used to construct fuzzy logic membership functions associated with each level of design risk. These membership functions are shown in Figure 9. Note that each level of risk is assigned a numerical range. For example, a "low" risk aircraft lies in the range of 0-25. These numerical ranges are used so that one airplane can be easily compared to another. As such, the numerical values assigned for risk cannot (at this time) be directly related to such things as component or life cycle cost. However, considering the complexity of the control system as a significant factor in the cost of the control system development and implementation, it is reasonable to assume that at least some relationship between cost and control risk exists.

Table 2 Control System Architectures and Risk

Control System	Usual Application	Risk
No Control Required	Satisfactory Bare-Airframe	Low
Pitch Damper	Damping	Medium
Accelerometer Feedback	Natural Frequency	Medium
Blended Signal Feedback	Damping and Natural Frequency	High
Proportional+Integral Control	Unstable Airplanes	Very High
Augmented Flap Schedule	Pitch Rate Zero Location	Very High

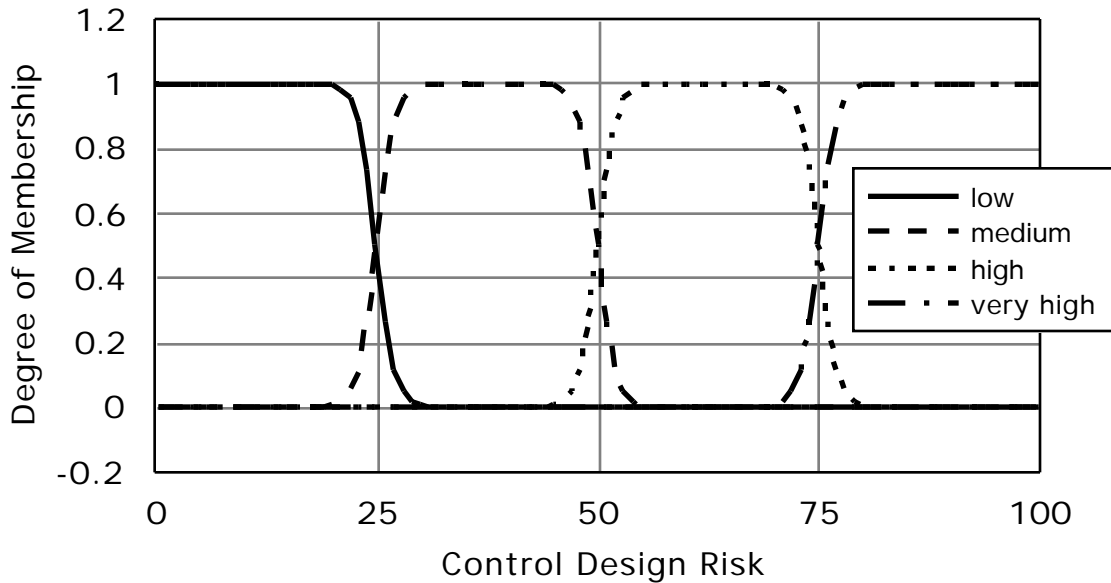

Figure 9 Control Design Risk Membership Functions

Fuzzy Logic Rules

This section describes each of the fuzzy logic rules that have been developed to assess flight control design risk for longitudinal-axis airplane models. Each rule is listed along with comments regarding the rule development. In particular, a root locus plot is shown in order to illustrate the control system structure that is needed to correct the flying qualities deficiency targeted by the particular rule.

The fuzzy logic rules are shown with the membership functions underlined in each antecedent (the IF side of the rule). These membership functions refer to those that were introduced in previous sections of this report. Also, the control risk assessment membership functions are underlined in the consequent (THEN side of the rule). The control risk membership functions were shown previously in Figure 9.

The fuzzy logic algorithm used for this work reports rules that are "fired" with the highest strength for each given configuration. The rules listed can be tracked to the rule description given in this section. As a result, the user can trace through the rulebase to determine the deficiencies of a particular airplane as well as the control system architecture needed to correct those deficiencies.

Rule 1: No Control Required

IF the short period poles are complex

AND the short period poles are stable

AND ζ_{sp} is within requirement

AND ω_{sp} is within requirement

THEN control risk is low.

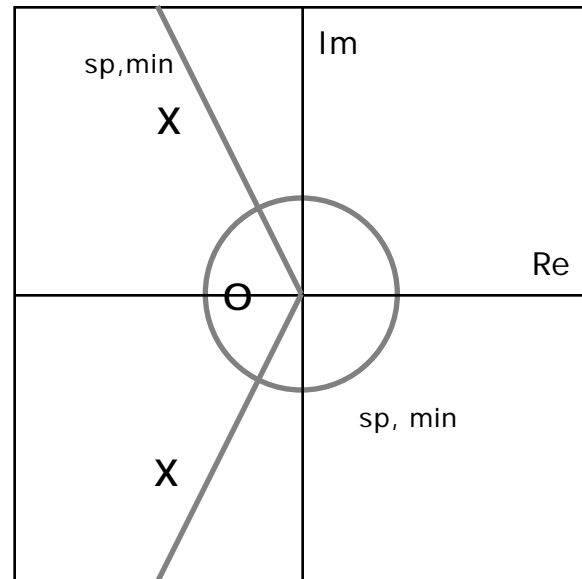

Comments:

For this case, the open-loop aircraft dynamics already meet the design requirements. Therefore, at most, only control stick blending would be required and no aircraft response sensors are needed.

Rule 2: No Control Required

IF the short period poles are real

AND the short period poles are stable
AND the short period poles are together

AND $\zeta_{sp 2}$ is within requirement

AND ζ_{sp} is within requirement

THEN control risk is low.

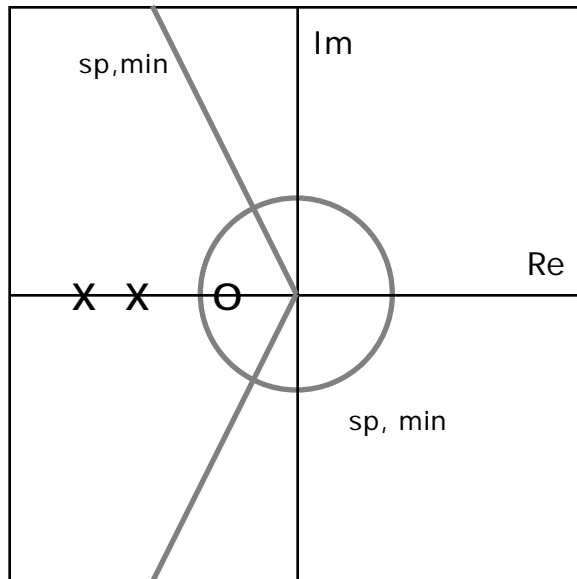

Comments:

Here is another case where the aircraft dynamics already meet the design requirements. When the short-period damping ratio is greater than unity, the short-period poles are real. However, the requirements allow a damping ratio of up to 1.2, so this configuration requires no control system.

Rule 3: Pitch Damper

IF the short period poles are complex

AND the short period poles are stable

AND ζ_{sp} is within requirement

AND ω_{sp} is below requirement

THEN control risk is medium.

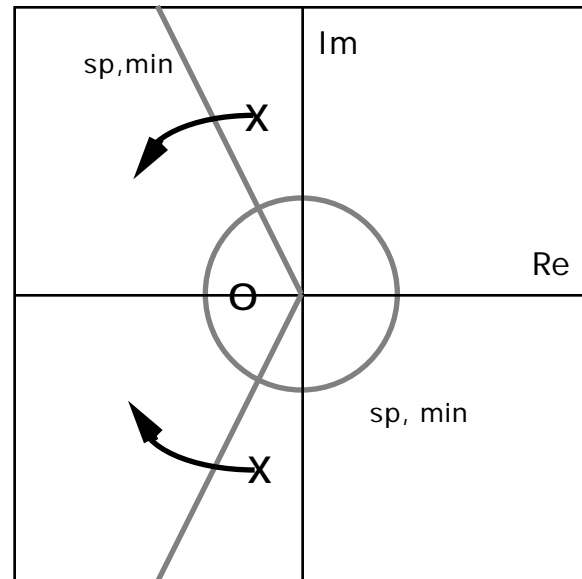

Comments:

This case depicts the classic use of a pitch rate damper to improve short-period damping ratio. The poles are complex and stable, but are located to the right of the minimum damping ratio boundary. Feedback of measured pitch rate to the elevator or horizontal tail is required to fix this deficiency.

Rule 4: Pitch Damper

IF the short period poles are complex
AND the short period poles are unstable
AND sp_2 is within requirement
THEN control risk is medium.

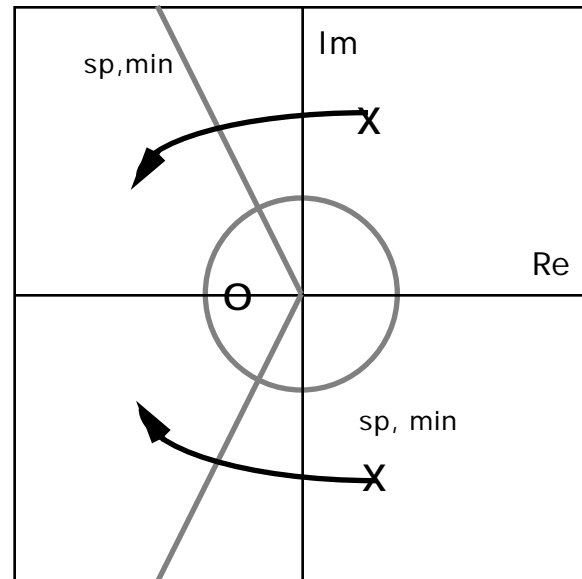

Comments:

It is also possible to stabilize an unstable configuration using a pitch damper. If the short-period roots are complex and located a sufficient distance from the origin, a pitch damper can be used to move the closed-loop poles into the stable region of the complex plane.

Rule 5: Accelerometer Feedback

IF the short period poles are complex

AND the short period poles are stable

AND ζ_{sp} is below requirement

AND ω_{sp} is within requirement

THEN control risk is medium.

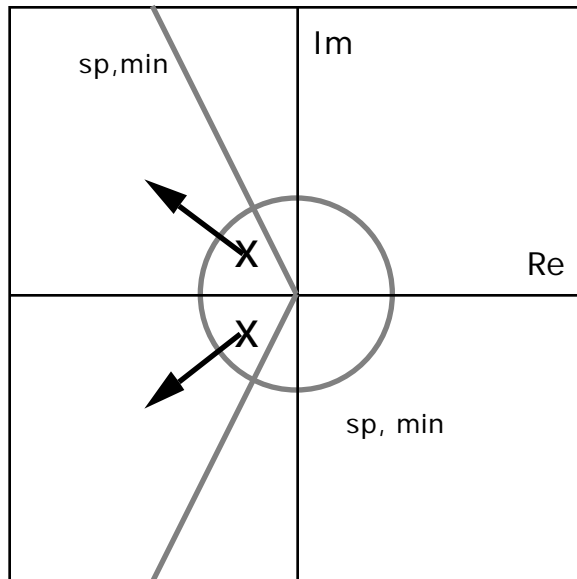

Comments:

When the short-period natural frequency is below the required minimum, an accelerometer feedback to the elevator, canard, or horizontal tail surface can be used to increase its magnitude. Because there is no zero in the acceleration transfer function, an increase in the feedback gain will increase the effective closed-loop natural frequency.

Rule 6: Accelerometer Feedback

IF the short period poles are real

AND the short period poles are stable

AND ζ_{sp} is above requirement

AND ω_{sp} is within requirement

THEN control risk is medium.

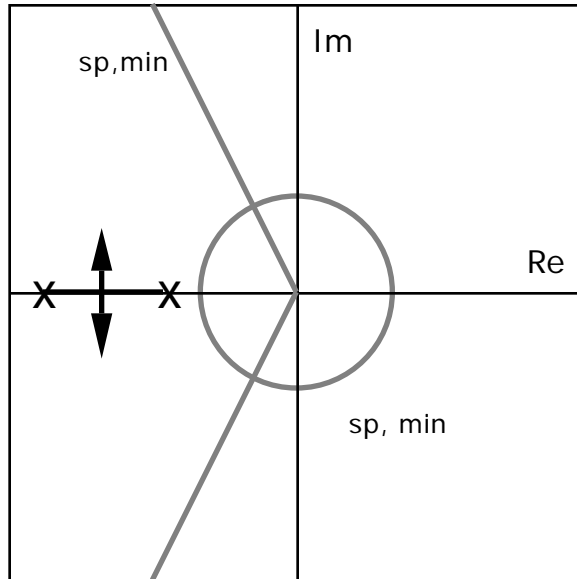

Comments:

This root locus describes the rather unusual case where the short period damping ratio is too high. Pilots do not like the resulting deadbeat response because it leads to rather abrupt accelerations. When the damping ratio exceeds the maximum value, the roots will be separated by a large distance on the real axis. An accelerometer can be used to reduce the damping ratio.

Rule 7: Accelerometer Feedback

IF the short period poles are real

AND the short period poles are stable

AND $\zeta_{sp 2}$ is below requirement

AND the short period zero is right of the poles

THEN control risk is medium.

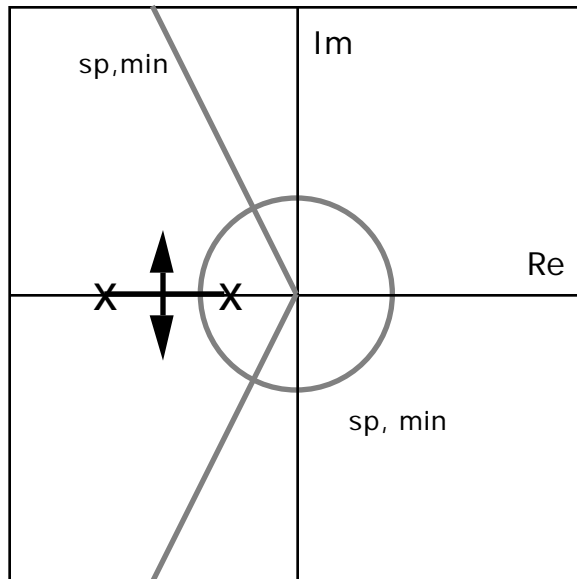

Comments:

It is possible that the short-period roots are real, with damping ratio exceeding unity, but still have deficient natural frequency. In the case where the short period zero is still to the right of the short period poles, the natural frequency can be increased at the cost of a slight reduction in damping ratio. However, because the damping ratio already exceeds unity, the reduction in damping ratio should be tolerable.

Rule 8: Blended Signal Feedback

IF the short period poles are complex

AND the short period poles are stable

AND ζ_{sp} is below requirement

AND ω_{sp} is below requirement

THEN control risk is high.

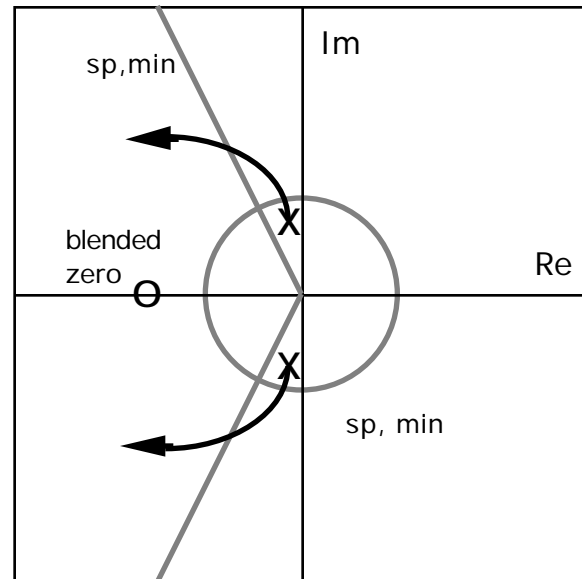

Comments:

In this case, the aircraft has deficient short-period damping and natural frequency. The remedy for this problem is to use a combination of pitch rate and normal acceleration feedback. This blending of two signals allows the designer to place a zero in the complex plane so that the short-period roots are drawn into the required region.

Rule 9: Blended Signal Feedback

IF the short period poles are complex
AND the short period poles are unstable
AND sp_2 is below requirement
THEN control risk is high.

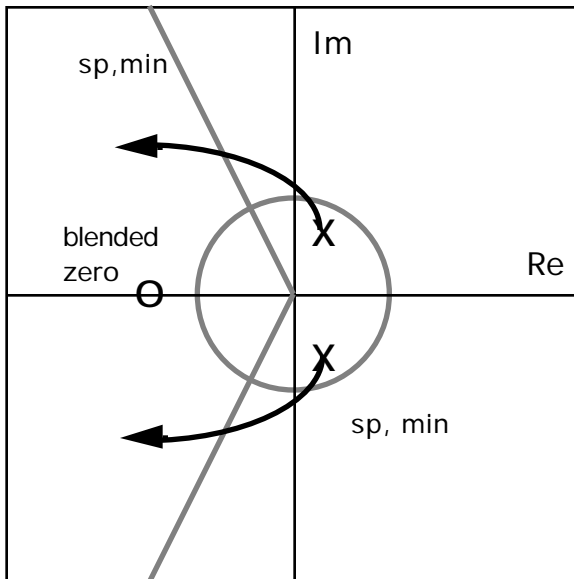

Comments:

When the short-period roots are complex, unstable, and close to the origin, it is difficult to use only a pitch damper to move the roots into the required region. Therefore, a normal acceleration feedback blended with the pitch rate feedback signals so that the roots are not only drawn into the left-half-plane, but also drawn away from the origin.

Rule 10: Blended Signal Feedback

IF the short period poles are real

AND the short period poles are stable
AND the short period zero is left of the poles

THEN control risk is high.

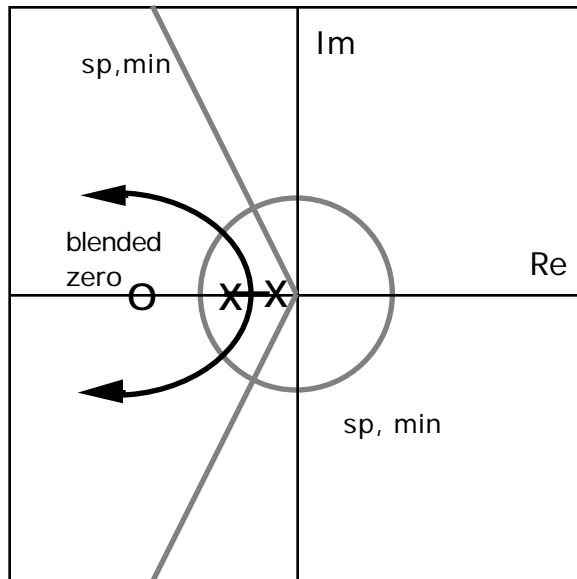

Comments:

When the short period poles are real, stable, and the short-period zero is to their left, the poles will have insufficient natural frequency. Because the short-period zero is to their left, a pitch damper could be used to improve natural frequency. However, most often the zero is too close to the poles and so acceleration feedback is needed to create a blended zero in the appropriate location far into the left-half-plane. As a result, a combination of the pitch damper and accelerometer feedback is needed in this situation.

Rule 11: Blended Signal Feedback

IF the short period poles are real

AND the short period poles are unstable
AND the short period poles are split
AND the short period zero is left of the poles

THEN control risk is high.

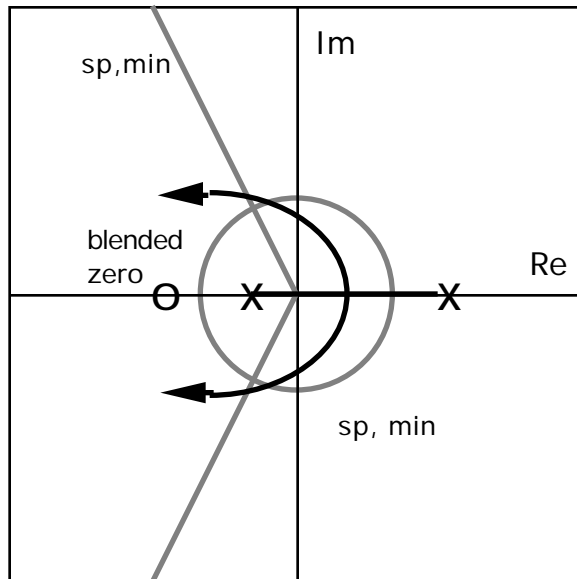

Comments:

In the case where one short-period pole is stable and the other is unstable, a pitch damper can be used to draw both roots back into the left-half-plane provided that the pitch rate zero is left of the poles. In general, however, the zero has to be moved farther into the left-half-plane to get closed-loop short-period roots with sufficient natural frequency. A blend of normal acceleration and pitch rate feedback usually achieves the desired result.

Rule 12: Blended Signal Feedback

IF the short period poles are real

AND the short period poles are stable
AND the short period poles are split
AND the short period zero is left of the poles

THEN control risk is high.

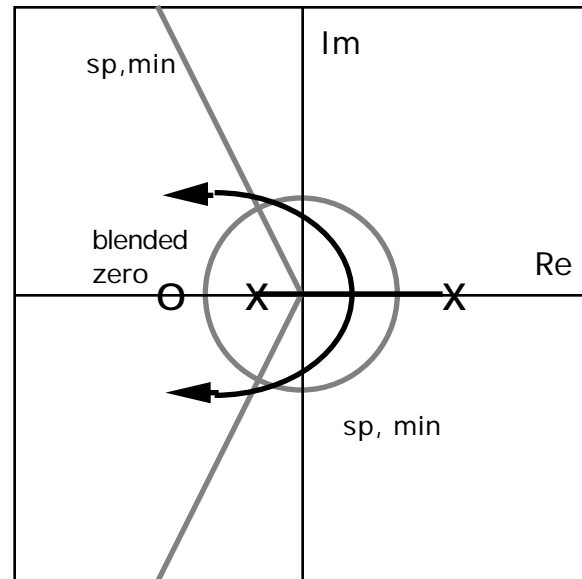

Comments:

This is the same situation as described in Rule 11. This rule is needed to duplicate Rule 11 because the split pole arrangement is possible with two different sequences of characteristic equation coefficients.

Rule 13: Blended Signal Feedback

IF the short period poles are real

AND the short period poles are unstable
AND the short period poles are together

THEN control risk is high.

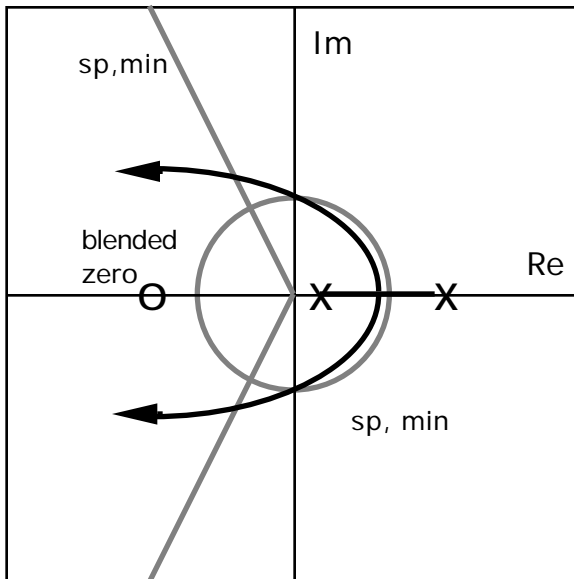

Comments:

A combination of normal acceleration and pitch rate feedback can also be used to stabilize the aircraft when both roots are unstable. The pitch rate zero will always be to the left of the roots in this case, but the location of the zero is probably insufficient to draw the closed-loop roots into the desired region. Consequently, the blended zero is chosen to make the root locus branches act appropriately.

Rule 14: Proportional + Integral Control

IF the short period poles are real

AND the short period poles are stable
AND the short period zero is between
the poles

AND sp_2 is below requirement

THEN control risk is very high.

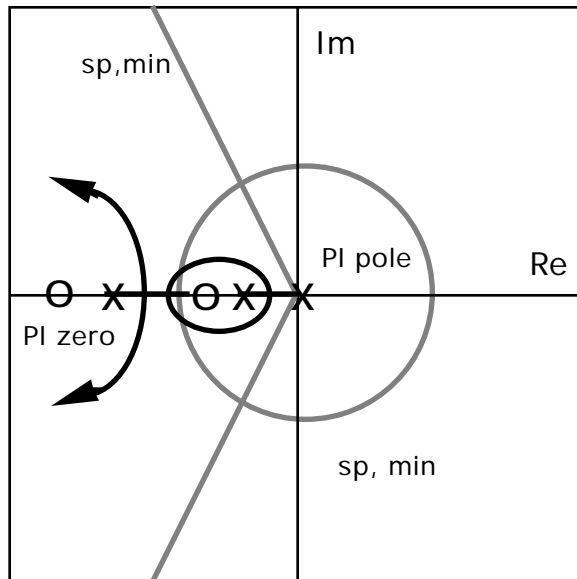

Comments:

When the pitch rate zero lies between the two real short-period poles, it is not possible to meet the necessary requirements with either the pitch damper or accelerometer feedback, or both. The proportional+integral control structure allows the control system designer to place a real zero and an integrator pole in the complex plane. The pole and zero of the control system allow the root locus branches to come together on the real axis before splitting into complex conjugates in the desired region.

Rule 15: Proportional + Integral Control

IF the short period poles are real

AND the short period poles are unstable
AND the short period poles are split
AND the short period zero is between
the poles

THEN control risk is very high.

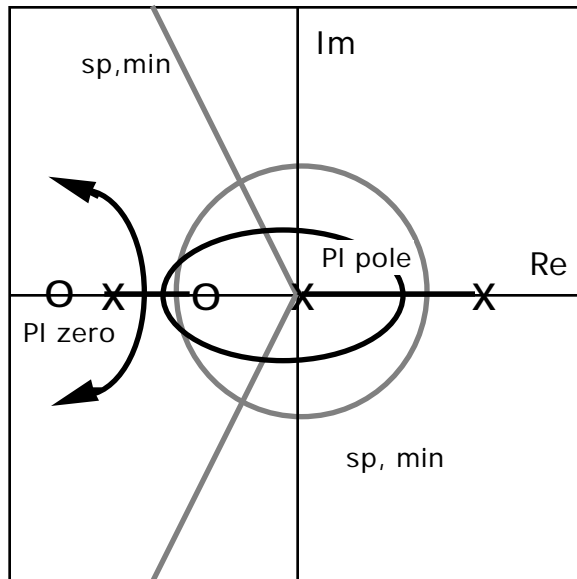

Comments:

A proportional+integral control structure is required when one short-period pole is unstable and the short-period zero is in-between the two poles. The proportional+integral zero is placed to the left of the stable short-period pole. This controller zero tends to draw the closed-loop characteristic roots into the desired region of the complex plane.

Rule 16: Proportional + Integral Control

IF the short period poles are real

AND the short period poles are stable
AND the short period poles are split
AND the short period zero is between
the poles

THEN control risk is very high.

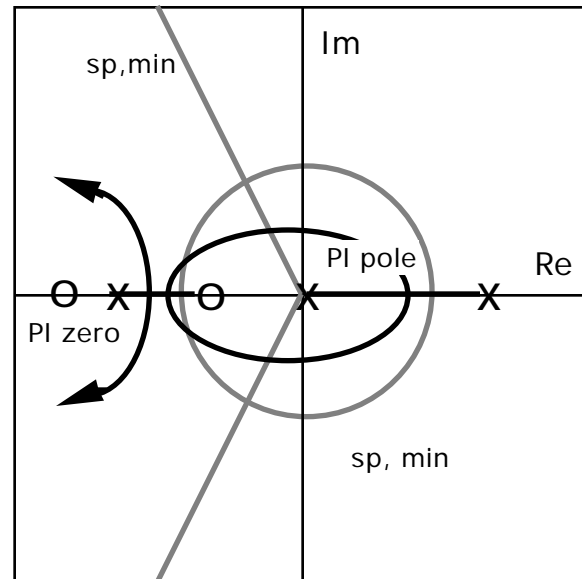

Comments:

This rule is the same as Rule 16. It must be included to account for the two characteristic equation coefficient sign sequences that lead to split unstable and stable pole configurations.

Rule 17: Flap Augmentation

IF short period zero is below
requirement

THEN control risk is very high.

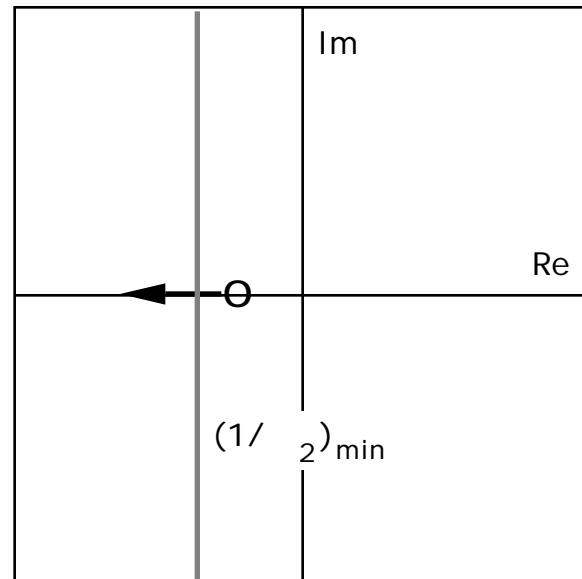

Comments:

This rule covers the location of the short period zero. If the location of this zero is below its minimum required value, a flap schedule or flap augmentation feedback is needed to move the zero above its minimum. Implementing an angle-of-attack to flap feedback controller is considered a "very high" risk control design.

Examples

The control system design risk assessment program has been implemented by a group of macro files within in the MATLAB computer-aided engineering environment. The five files needed to run the program are called: `crisk.m`, `defuzzy.m`, `fuzrisk.m`, `fuzzy.m`, and `ruleval.m`. They are included in the Appendix of this report. None of the optional MATLAB toolboxes are needed to run the program. In fact, these files will also run without alteration on the student versions of MATLAB .

Consider, as an example, the XB-70 supersonic bomber. The stability derivatives for this airplane when it is cruising at 40,000 ft, Mach 2.2 (supersonic) are given by:

$$Z = -0.52 \text{ (1/sec)}$$

$$M = -8.58 \text{ (1/sec}^2\text{)}$$

$$M_q = -0.73 \text{ (1/sec)}$$

$$M_e = -4.62 \text{ (1/sec}^2\text{)}$$

The transfer function coefficients are then computed as,

$$a = -Z = 0.52 \text{ (1/sec)}$$

$$b = -\frac{Z + M_q}{2} = 0.63 \text{ (1/sec)}$$

$$c = Z M_q - M = 8.96 \text{ (1/sec}^2\text{)}$$

The following text shows a sample run of the control system design risk assessment program. The user is asked to supply values of the pitch rate transfer function coefficients a , b , and c . The program then computes the resulting control system design risk. A list of rules is also printed to the screen along with the associated strength of the rule as long as the strength of the rule is greater than 0.02. In the following example, the user input is specified by bold type.

The program is executed by starting the macro file called 'crisk.m' at the MATLAB prompt.

```
»crisk
```

```
*****  
Control Design Risk Assessment Program  
*****
```

Please enter the numerator coefficient (a): **0.52**

Please enter the denominator s1 coefficient (b): **0.63**

Please enter the denominator s0 coefficient (c): **8.96**

rules fired	strength
3	0.8377
1	0.1622
17	0.0245

The final control design risk value is 34.55

»

For this example, the final control design risk value predicted for the XB-70 aircraft is about 35. This value means that the aircraft lies in the "medium" design risk region. This value can be compared to other existing or prototype aircraft to yield a relative indication of increased or decreased design risk.

More information about the required aircraft control system can be obtained by checking the rules that were fired that led to the predicted control risk value. For the XB-70 example, Rule #3 and Rule #1 fired with the highest strengths. The strength of a rule indicates to what degree the antecedents (left side) of the rule are true. Sorting through the rule descriptions discussed previously, we find that Rule #3 involves the case when the short period damping is low. A pitch damper control law (medium risk) is needed to correct this problem. Therefore, we know that the control system of the airplane must have at least a pitch rate sensor and one feedback gain.

Rule #1 fired with the second highest strength of 0.16. This rule is associated with the case where no control system is required. As a result, we can conclude that the short-period poles of the XB-70 in this flight condition are probably near the short period damping ratio boundary. When the poles are near the boundary, both Rule #1 and #3 will fire and their relative strengths will indicate how close the poles are to the boundary. For this case, the damping ratio of the XB-70 is 0.21 while the boundary is at 0.35. Since the damping ratio of the airplane is lower than the requirement, Rule #3 will fire with a higher strength than Rule #1.

The longitudinal control system for the XB-70 is shown in Figure 10. Note that the control system includes a feedback of pitch rate to the elevator. This loop demonstrates the pitch damper that is needed for high-speed flight. However, also note that the control system appears slightly more complicated than is predicted by the control system design risk assessment method. The complexity of the final control system is under-predicted because we have only considered one flight condition. The predicted control system design risk varies with flight condition because the airplane stability derivatives vary with flight condition. The flight condition that leads to the highest risk value will likely define the actual flight control system architecture needed for the airplane.

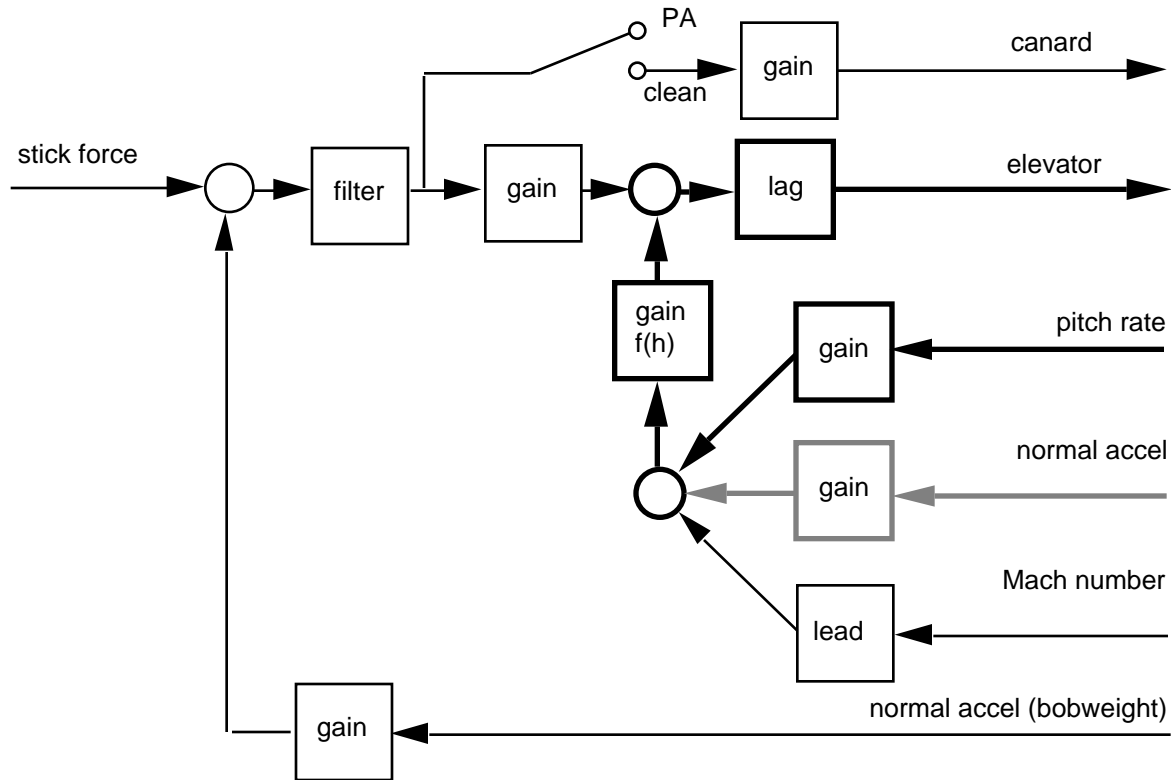

Figure 10 XB-70 Longitudinal Control System

Consider a second flight condition of the XB-70, where the aircraft is cruising at sea level, Mach 0.8 (subsonic). The stability derivatives of the airplane in this case are:

$$Z = -1.19 \text{ (1/sec)}$$

$$M = -2.54 \text{ (1/sec}^2\text{)}$$

$$M_q = -1.75 \text{ (1/sec)}$$

$$M_e = -7.46 \text{ (1/sec}^2\text{)}$$

The transfer function coefficients are then,

$$a = -Z = 1.19 \text{ (1/sec)}$$

$$b = -\frac{Z + M_q}{2} = 1.47 \text{ (1/sec)}$$

$$c = Z M_q - M = 4.62 \text{ (1/sec}^2\text{)}$$

and the control system design risk is predicted by the following user input.

»crisk

```
*****  
Control Design Risk Assessment Program  
*****
```

Please enter the numerator coefficient (a): **1.19**

Please enter the denominator s1 coefficient (b): **1.47**

Please enter the denominator s0 coefficient (c): **4.62**

rules fired	strength
5	0.5908
1	0.4092

The final control design risk value is 27.89
»

The subsonic flight condition leads to a "medium" design risk value of about 28. This result is comparable to the supersonic case prediction of 34. However, note that in the subsonic case, Rule #5 was fired with the highest strength. This rule is associated with the need for an accelerometer feedback. Therefore, one can conclude that the pitch damper is needed for supersonic flight and an accelerometer is needed for subsonic flight. This result explains the additional normal acceleration feedback path shown in Figure 10.

Several additional aircraft are analyzed in the following tables. These aircraft configurations can be used as a comparison to new prototypes or other existing designs.

Table 2 Control Risk for Large, High-Speed Aircraft

aircraft	a	b	c	Rules Fired	Strength	Risk
B-1	0.83	1.32	11.40	1	0.62	22.3
				3	0.38	
XB-70 (PA)	0.58	0.86	2.54	1	0.90	17.8
				3	0.10	
				8	0.03	
				5	0.03	
XB-70 (subsonic)	1.19	1.47	4.62	5	0.59	27.9
				1	0.41	
XB-70 (supersonic)	0.52	0.63	8.96	3	0.84	34.6
				1	0.16	
				17	0.02	
SCAS (PA)	0.36	0.31	0.55	5	0.69	61.1
				17	0.63	
				8	0.31	
				9	0.04	
SCAS (high speed)	0.20	0.18	1.76	17	0.99	61.4
				3	0.86	
				4	0.14	
				1	0.07	

Table 3 Control Risk for Highly Maneuverable Aircraft

aircraft	a	b	c	Rules Fired	Strength	Risk
A-4D (PA)	0.82	1.20	11.49	1	0.51	24.7
				3	0.49	
A-4D	0.76	1.12	13.82	3	0.64	28.2
				1	0.36	
A-7 (PA)	0.73	0.65	3.10	1	0.56	27.8
				3	0.44	
				8	0.10	
				5	0.10	

A-7	1.09	1.00	9.92	3 1	0.59 0.41	27.2
F-4	0.53	0.64	8.15	3 1	0.81 0.18	33.6
F-18	0.39	0.38	2.01	3 17 1 4	0.72 0.43 0.28 0.02	47.9
X-29 (PA)	0.36	0.28	-3.00	16 17 15	0.94 0.63 0.06	87.5
X-29 (high speed)	1.67	1.19	-34.6	16	1.00	87.5
Gripen	0.37	0.35	-6.49	16 17 15	0.97 0.56 0.03	87.5

Table 4 Control Risk for Subsonic Commercial Aircraft

aircraft	a	b	c	Rules Fired	Strength	Risk
DC-8 (PA)	0.54	0.85	2.62	1 3	0.89 0.11	17.8
DC-8	0.68	1.04	5.76	1 3	0.73 0.27	19.9
Learjet M24	0.66	1.00	7.96	1 3	0.51 0.49	24.8
Boeing 747	0.52	0.58	1.54	1 5 8 3 17	0.60 0.40 0.20 0.20 0.02	31.3

Suggested References

Anderson, M.R., Suchkov, A., Einthoven, P., and Waszak, M.R., "Flight Control System Design Risk Assessment," AIAA Paper No. 95-3197, AIAA Guidance, Navigation, and Control Conference, Baltimore, MD, Aug. 1995.

Anderson, M.R. and Mason, W.H., "An MDO Approach to Control-Configured-Vehicle Design," AIAA Paper No. 96-4058, 6th AIAA/USAF/NASA/ISSMO Symposium on Multidisciplinary Analysis and Optimization, Sept. 1996.

Williams, T., "Fuzzy Logic is Anything but Fuzzy," *Computer Design*, April 1992, pp. 113-127.

Beaufriere, H. and Soeder, S., "Longitudinal Control Requirements for Statically Unstable Aircraft," 38th National Aerospace and Electronics Conference (NAECON), May 1986.