

Haftka's Helicopter Project: Combined Theoretical/Experimental Design

William H. Mason
Aerospace and Ocean Engineering
Virginia Polytechnic Institute and State University
Blacksburg, VA 24061
mason@aoe.vt.edu

Abstract

A helicopter design project is described that combines computational modeling, optimization, design of experiments theory, fabrication, test, and analysis of the results, including statistical analysis. This is all done in a classroom environment in a reasonable number of class periods. Originally introduced by Professor Rafi Haftka at the University of Florida, this paper describes the version of the project carried out in the Fall of 1997 at Virginia Tech. The purpose of this paper is to expose a wide spectrum of educators to this project. Our experience with this project was very good and we provide enough details to allow easy implementation elsewhere.

Introduction

Real world product development efforts require analytic models, analytical/computational design and an experimental development program to produce a quality product. It is a challenge to find a class project that simulates the flavor of this process. At the University of Florida, Professor Raphael Haftka has introduced a project that serves this purpose in his senior/graduate level course "Experimental Optimum Engineering Design".¹ In the Fall of 1997 a simplified version of the project was used in the "Introduction to AOE Design" course at Virginia Tech after Professor Haftka sent us a draft version of a paper describing the project. The project is perfectly suited for use in engineering design and product development classes, and the ASEE Conference provides an opportunity to make a wide spectrum of educators aware of this project. One of the key components in the class is the use of statistical methods. Although industry has been requesting more use of statistics in the engineering program, many aerospace engineering courses are still weak in the use of statistical methods. This project builds on previous projects used in the statistics community to illustrate design of experiments theory and process variation.^{2,3} The project is also multidisciplinary, an aspect of engineering we have been stressing at Virginia Tech for several years.⁴ I am aware of one other similar project. The U.S. Air Force Academy has used design of experiments theory to develop a test matrix for gliders.⁵

Previously in the "Introduction to AOE Design" course we had used experimental projects with a very weak math model basis. They included a tower project introduced by Kim Aaron of JPL/Cal Tech at a USRA meeting, and balsa wood gliders. For students without any aerodynamics or stability and control courses, the balsa wood glider was built without an adequate theoretical motivation to provide significant insight. In addition, finding a controlled environment to fly planes during the class period is essentially impossible. Thus the project described here is perfectly suited to exposing the students to a more realistic product design process.

In this paper we briefly describe the "Introduction to AOE Design" course, the problem to be solved, the implementation of the project, and the theoretical and experimental details. Enough detail is given for the project to be easily implemented by harried teachers in their own courses.

The Course

The Aerospace and Ocean Engineering Department gave a one credit pass/fail, elective, nominally-sophomore class that provided an introduction to design methods and aerospace and

ocean engineering. Typically the class had 20-25 students, and eventually attracted a mix of students from other majors. It met once a week for two hours. The class was introduced at the request of students for two reasons. First, the seniors complained that they weren't ready for the capstone senior design and it was hoped this would help them. Second, we started using some freshmen in the second semester of the senior design class to help them get some insight into the engineering process, and motivate the need for the engineering science classes.^{6,7} Those students wanted to continue some sort of design activity. This course is now being replaced by a more traditional three credit required introductory course. Two aspects are worthy of note. The mix of seniors and freshman worked well, a class of same year students is not nearly as good (What if companies segregated their workers by number of years of experience? Would that make sense?). Also, the freshman-senior program has been expanded by Prof. Marchman to include sophomores and juniors, as well as seniors from other majors and an international element.⁸

The Project

The idea revolves around the construction of paper helicopters. These helicopters can be defined by a few key design parameters such as rotor radius, and tail length and width. Figure 1 shows the helicopter and provides some nomenclature. The project is done in several parts. In addition, the class is divided into teams, and they do each part as a team. We had four teams with two to four students on each team.

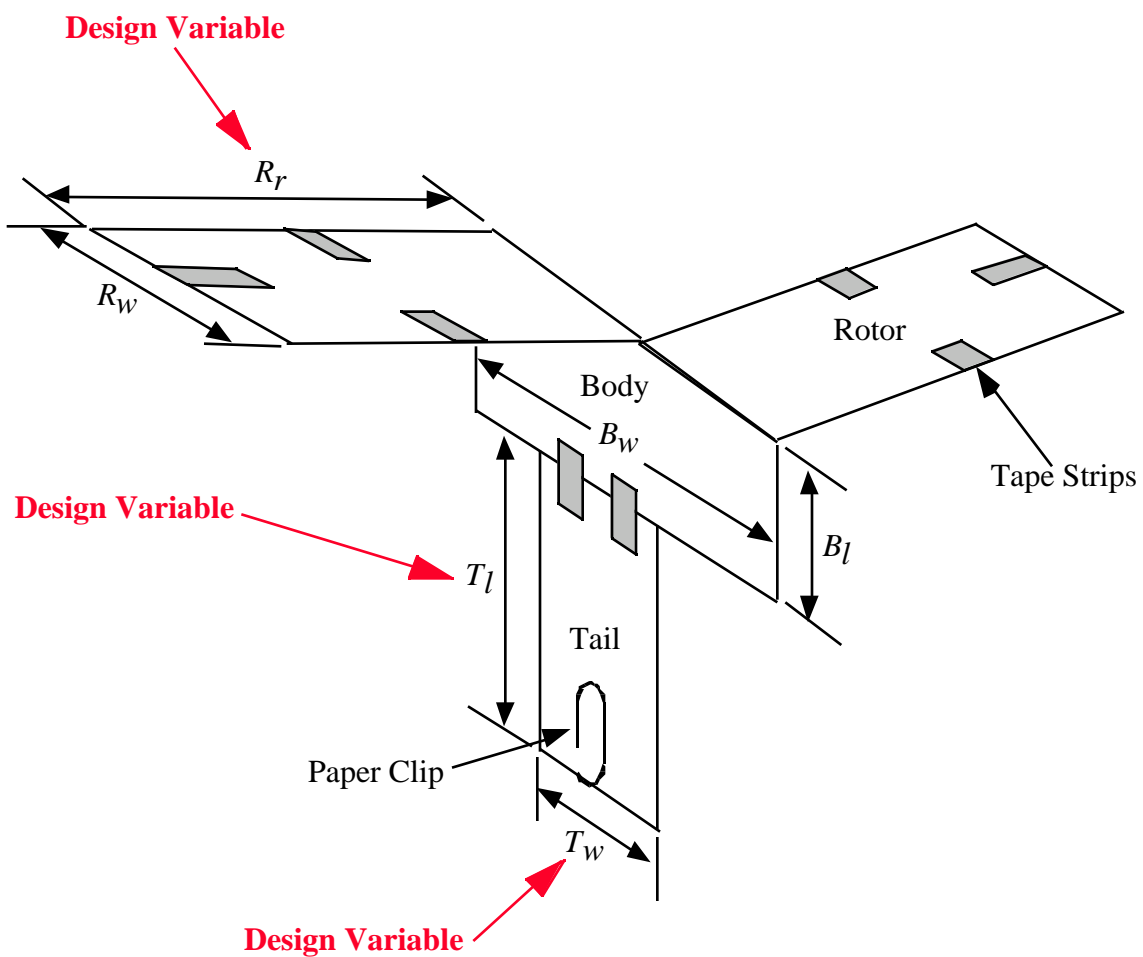

Figure 1. The "Helicopter"¹

First, we derive the math model for the students, mainly sophomores that haven't had an aerodynamics course yet. Then, using the three design variables listed above, and the math model, we find values of the design parameters which maximize the descent time. The students in the class at Virginia Tech used the solver in **Excel** to find the optimum values of the design parameters. Next, we built the optimum design found in **Excel** and tested it.

Working around the optimum as a baseline, we used design of experiments theory to develop a matrix of designs for the experimental development program. Each team built the matrix of designs and then tested them. They then used the results to do some evaluation of the results, picking a final design. To do the statistical analysis, in addition to **Excel**⁹ we used **JMP IN**,¹⁰ which is the student version of the SAS package **JMP**.

The Plan

Week Number 1:

- Develop a math model of the system and determine the optimum values of the design variables for the model using the solver in **Excel**.
- Build and evaluate the “optimum” model. Fly it in the Hancock Hall atrium (find the height from the launch point to the floor) and record the time. Do 5 flights, record the time for each. Determine the average time and the standard deviation.

Week Number 2:

Talk about the validity of the assumptions used in the math model, and then:

- Develop an experimental program using a matrix of designs.
- Build the matrix of designs (*this took longer than I expected*)

Week Number 3:

- Conduct a test program, flying each design five times and averaging the results. (*this was done much faster than I expected, less than an hour to fly all the designs*)
- Talk about modeling of the experimental result.
- Find the optimum helicopter as predicted by the experimental program, and:
- Build the optimum and test it. (*not actually done, we ran out of time*)
- Assess the results obtained from the combined theoretical/experimental development program.

The Details

The Math Model

We were able to find an atrium where we had an 18 1/2 foot drop distance, and thus we ignored the time for the helicopter to achieve steady state conditions after the drop. Thus the math model was simply the equilibrium condition:

$$D = W. \tag{1}$$

The drag is found using the standard definition,

$$D = 1/2 \rho V^2 S C_D, \tag{2}$$

where ρ is the air density, V is the downward velocity, S is the area spanned by the rotor, $S = R_r^2$, where R_r is the radius of the rotor, and following Haftka,¹ the drag coefficient, C_D is

assumed to be 1.1. We find the velocity from Eq. (1) by substituting Eq. (2) into Eq.(1) and solving for V :

$$V_{ss} = \sqrt{\frac{2W}{R_r^2 C_D}} \quad (3)$$

Clearly, maximizing the descent time is equivalent to minimizing the velocity.

Next, we need to obtain an expression for the weight, W . It is given as the sum of the wing, body, tail and paper clip weights:

$$W = W_{wing} + W_{body} + W_{tail} + W_{paper\ clip} \quad (4)$$

The weights of the body and tail are obtained by multiplying their areas by the paper density

$$W_{body} = B_l B_w \text{ paper}g \quad (5)$$

$$W_{tail} = T_l T_w \text{ paper}g \quad (6)$$

while the weight of the paper clip is measured. Following Haftka,¹ the weight of the wing (rotor), “was assumed to increase cubically with its radius to reflect strength and stiffness requirements in a real helicopter”,

$$W_{wing} = W_{wing0} \left(\frac{R_r}{R_{r0}}\right)^3 \quad (7)$$

where R_{r0} is the nominal rotor radius, and W_{wing0} is the corresponding nominal rotor weight. Thus, the total weight, Eq.(4), can be expressed in terms of the design variables as

$$W = W_{wing0} \left(\frac{R_r}{R_{r0}}\right)^3 + B_l B_w \text{ paper}g + T_l T_w \text{ paper}g + W_{paper\ clip} \quad (8)$$

Experimental Design

After we’d flown the helicopters obtained from the math model and optimization, we started the experimental development program. We gave the students an admittedly superficial introduction to design of experiments methods, and a typical sheet generated by **JMP IN** to use to construct the range of experiments. Figure 2 is the visualization of the matrix of designs that were built and flown. We pointed out that not all of the possible combinations of designs were included. And gave an example showing how with the addition of more design variables it quickly becomes impossible to consider every combination of design variables. The design illustrated in Fig. 2 is a Box-Behnken design, which was selected because it resulted in making the smallest number of designs. Note that it “trims off” the corners of the design space. Table 1 shows the output from **JMP IN**, that we actually used, together with the results from one of the groups to be presented below. Here, the design variables are given in terms of their upper and lower bounds, which we provided for the students.

Results

Working in teams of from two to four students, they worked in our design lab, as shown in Fig. 3, to obtain the optimum from **Excel**. Figure 4 shows them making the helicopters. They then timed the flights for a drop of 18 1/2 feet, typical of atriums found in modern buildings. For our case, the students found that the flight time for the optimum case was predicted to be 5.33 seconds. Teams obtained average values from five helicopter flights of 5.2, 6.1, 7.3, and 7.4 seconds. This was a remarkable range of times for the flights of helicopters that were supposed to be identical, and set the stage for the next part of the project.

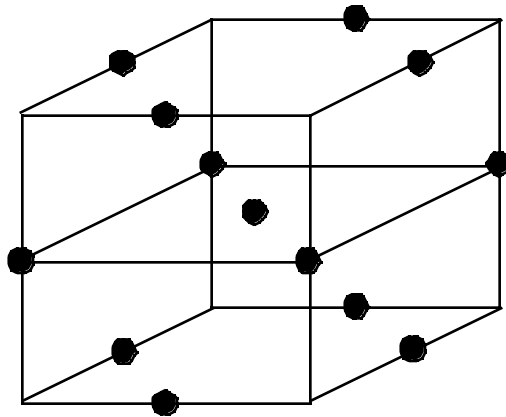

Figure 2. Simple Experimental Design

Table 1. Box-Behnken Design Matrix from **JMP IN**
(data from deGuzman, Lee and Laurence)

Design	Pattern	Block	Rr	Tw	TI	Time
1	--0	1	-1	-1	0	4.528
2	-+0	1	-1	1	0	4.412
3	+-0	1	1	-1	0	6.182
4	++0	1	1	1	0	5.848
5	0--	1	0	-1	-1	4.266
6	0-+	1	0	-1	1	5.156
7	0+-	1	0	1	-1	4.710
8	0++	1	0	1	1	4.8
9	-0-	1	-1	0	-1	4.05
10	+0-	1	1	0	-1	5.09
11	-0+	1	-1	0	1	4.87
12	+0+	1	1	0	1	6.05
13	000	1	0	0	0	4.82
14	000	1	0	0	0	4.81
15	000	1	0	0	0	4.83

Building on the initial results, we talked about process variation and then undertook the design of experiments development program. Each team built the 13 different helicopters defined in Table 1 above, and tested this matrix of designs. They then reported the average time of five flights for each different design. Three teams got a better helicopter design from the design of experiments approach, while one team got their highest flight time from the analytic parameters. Figures 4 and 5 show the teams doing the flight testing.

We then looked at the results by fitting the flight test data. They used **Excel** themselves, but were shown results from **JMP**, a more sophisticated statistical analysis package. It became clear that the key to slowing the helicopter down was to increase the rotor radius. However, not evident in the numerical results, when the rotor radius became too large, the helicopters became unstable, and began “flopping” rather than flying. This is shown in Fig. 7, from **JMP IN**, which shows that based on the results from the test program, The rotor radius is the primary design variable, possibly an obvious result!



Figure 3. The students with Chuck Baker, using the **Excel** solver to get the “optimum”



Figure 4. Students fabricating the helicopters



Figure 5. Carefully launching the helicopters

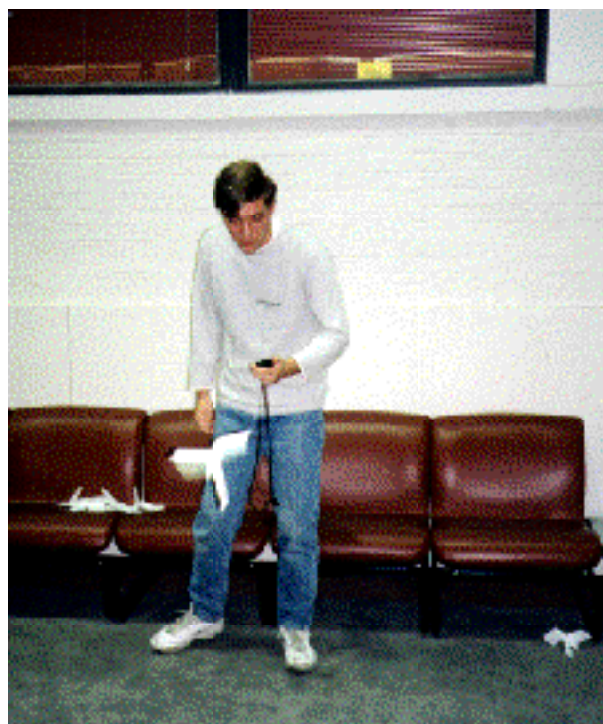

Figure 6. Timing the flight

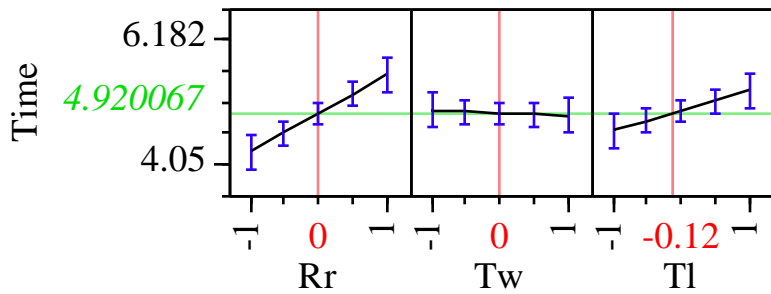

Figure 7 Results from **JMP IN** screening, showing the effects of three design parameters

Table 2. Response Surface Parameter Estimates from **JMP IN**

Parameter Estimates				
Term	Estimate	Std Error	t Ratio	Prob> t
Intercept	4.82	0.118601	40.64	<.0001
Rr	0.66375	0.072628	9.14	0.0003
Tw	-0.04525	0.072628	-0.62	0.5606
Tl	0.345	0.072628	4.75	0.0051
Rr*Rr	0.35225	0.106906	3.29	0.0216
Tw*Rr	-0.0545	0.102711	-0.53	0.6184
Tw*Tw	0.07025	0.106906	0.66	0.5401
Tl*Rr	0.035	0.102711	0.34	0.7471
Tl*Tw	-0.2	0.102711	-1.95	0.1091
Tl*Tl	-0.15725	0.106906	-1.47	0.2013

Table 3. Response surface analysis from **JMP IN**,

Summary of Fit	
RSquare	0.961477
RSquare Adj	0.892136
Root Mean Square Error	0.205423
Mean of Response	4.961467
Observations (or Sum Wgts)	15

Tables 2 and 3 contain some of the information that **JMP IN** provides. Table 3 contains the results from creating a quadratic fit to the data, a so-called response surface. The column called “Estimate” is the coefficient of each term in the response surface, so that a quadratic polynomial can be constructed. The other columns provide the results of the statistical analysis of the data. Of particular importance, the last column shows that there are three key terms associated with the design, the terms are R_r , T_l , and R_r^2 . The other terms are poorly estimated and apparently are only weakly connected to the design. Table 3 provides more statistical information. In particular, it contains both the R-square and adjusted R-square values. Since the value of the adjusted R-squared is significantly less than one, we conclude that the fit to the data is not particularly good.

In a more advanced class the formulation of the function to be fit would be examined, but in this class, it was simply stated that the fit was not very good.

Finally, what was the outcome of the theoretical vs. experimental performance? Three teams got better designs from the experimental program than from the computational/theoretical model. However, one team found that the theoretical design was the best. It was remarkable that given the same problem, there was such a large variation in the results. This provided an excellent starting point for realizing the importance of variation in product design.

Conclusions

This project combines a number of key aspects of the design process. The students are able to develop theoretical models of the system, develop a rational experimental development program, and then make and test the designs. Software such as **Excel** and **JMP IN** allow the students to carry out the math easily. It is a good way of introducing statistics into the educational process. In doing the test, it was hard to control the students. One of the lessons was that the students wanted to undertake ad hoc improvements. They immediately wanted to start cambering and twisting the rotor blades. Finally, helicopters can be flown in a variety of locations. I have always had problems finding a place to fly model airplanes in the late fall or winter time in Blacksburg.

Acknowledgments

I would like to acknowledge Rafael T. Haftka of the University of Florida for telling me about this project and sharing a draft copy of the paper he and his student are writing for an upcoming conference. Chuck Baker, a graduate student in Aerospace and Ocean Engineering at Virginia Tech was the assistant for the class and did most of the work implementing our version of this project.

References

1. Siorek, T.L., and Haftka, R.T., "The Great Paper Helicopter - Experimental Optimum Engineering Design Problem," to be presented at the 7th AIAA/USAF/NASA/ISSMO Symposium on Multidisciplinary Analysis & Optimization, St. Louis, MO Sept. 2-4, 1998
2. Box, G.E.P., "Teaching Engineers Experimental Design with a Paper Helicopter," Report No. 76, Center for Quality and Productivity Improvement, University of Wisconsin, 1991.
3. Fricker, Ronald, "Demonstrating Experimental Design, or, Go Fly a Helicopter," Yale University, Dept. of Statistics, PO Box 208290, New Haven, Connecticut 06520-8290, 7 August 1997
4. W.H. Mason, Zafer Gürdal and R.T. Haftka, "Experience in Multidisciplinary Design Education," ASEE Annual Conference, Monday, June 26, 1995, Anaheim, CA For a postscript file of this paper, look at: http://www.aoe.vt.edu/aoe/faculty/Mason_f/MRNR95.html
5. Winn, R.C., Fernaud, J.M., Hecker, J.B., Plumley, R.L., Bernardi, L., Dziuban, S., and Schmidt, S., "Planned Experimentation in Aircraft Design," *Computers in Education Journal*, Vol. 1, No. 4, Oct.-Dec. 1991, pp. 33-40.
6. Marchman, J.F. III, and Mason, W.H., "Incorporating Freshman/Senior Design into the Aerospace Curriculum," ASEE Annual Conference, Edmonton, Alberta, Canada, June 25, 1994.

7. Marchman, J.F. III, and Mason, W.H., “Freshman/Senior Design Education,” *International Journal of Engineering Education*, Vol. 13, No. 2, 1997.
8. Marchman, J.F. III, “International Partnerships in Design Education,” Session 1202, 1998 ASEE Annual Conference and Exposition, Seattle, WA, June 1998.
9. Gottfried, B.S., *Spreadsheet Tools for Engineers*, McGraw-Hill, New York, 1996.
10. Small, J., and Lehman, A., *JMP Start Statistics, A Guide to Statistical and Data Analysis Using JMP and JMP IN Software*, Duxbury Press, Belmont, 1996.

Biographical Information

WILLIAM H. MASON is a Professor in the Aerospace and Ocean Engineering Department at Virginia Tech. He teaches several design courses and Applied Computational Aerodynamics. Prior to coming to Virginia Tech he spent 15 years in industry at the Grumman Aerospace Corporation. His research is in multidisciplinary design, vehicle technology integration and applied aerodynamics. <http://www.aoe.vt.edu/aoe/faculty/masfac.html>