

Gyro Board

Tom Mattick – UW (Dawgstar)
[206-543-6181, mattick@aa.washington.edu]

6-10-02
revised 7-15-02

NOTE: Connector names in this document and other board documents refer assignments made for each CEE board schematic by the board designer. Several boards may have the same connector name (e.g., "P2"), so all connector references will also include board name.

Description

The Gyro board is a CEE board which plugs into the CEE backplane. Its main function is to interface with the 3 gyros, condition gyro signals, and send the conditioned signals to the I/O board, for use by the ACDS. For UW and VT, the board also interfaces with the magnetometer board, conditions its signals, and send conditioned magnetometer signals to I/O board. Although this functionality is built into USU's board, it can be ignored. The gyro board also monitors gyro currents at +5V, -5V, and sends a warning signal on the backplane if these currents are out of bounds; a logic input can then be activated to shut down the board. The same type of current monitoring circuitry is used on the gyro board to monitor mag board current at +12V (can be ignored by USU).

In addition to the backplane interface (gyro connector P1), the board has three "top connectors" - P3 (10-pin interface to mag board), P4 (10-pin, interface to I/O board), and P2 (20-pin "side connector", interface to gyros and gyro temperature sensors). The placement of these connectors is shown below. For UW, mating connectors with free-hanging leads (with labels for pin number) are also supplied. Positions of these connectors on the gyro board are shown below:

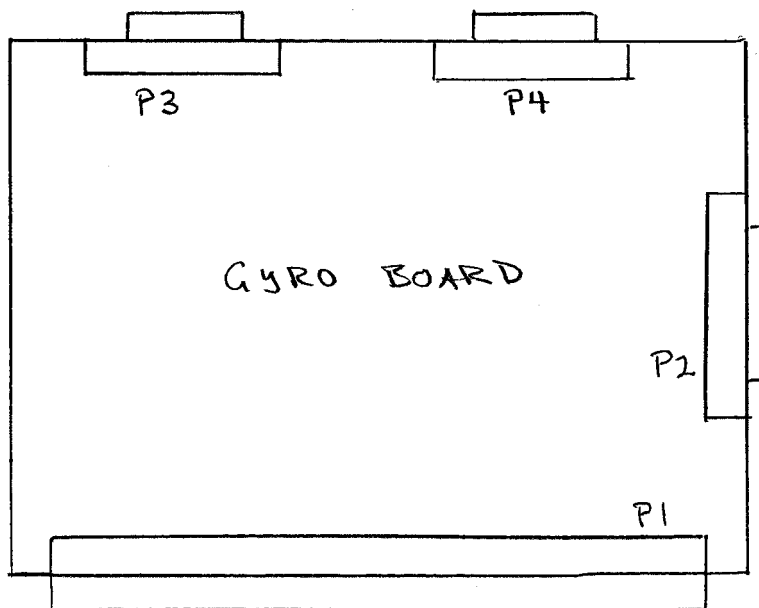

Gyro Board Connectors

Gyro board connectors P3 and P4 are each 10-pin connectors from Airborn (WTB10PR11SY), and the mating connectors are Airborn WTKA10SSY which have solder connections for leads which go to mag board (P3) or I/O board (P4). For UW, these mating connectors are pre-wired, with leads labeled.

Below is shown the pin numbering of the mating connectors at P3 and P4 (26-pin version is shown - all that was available from Airborn documentation).

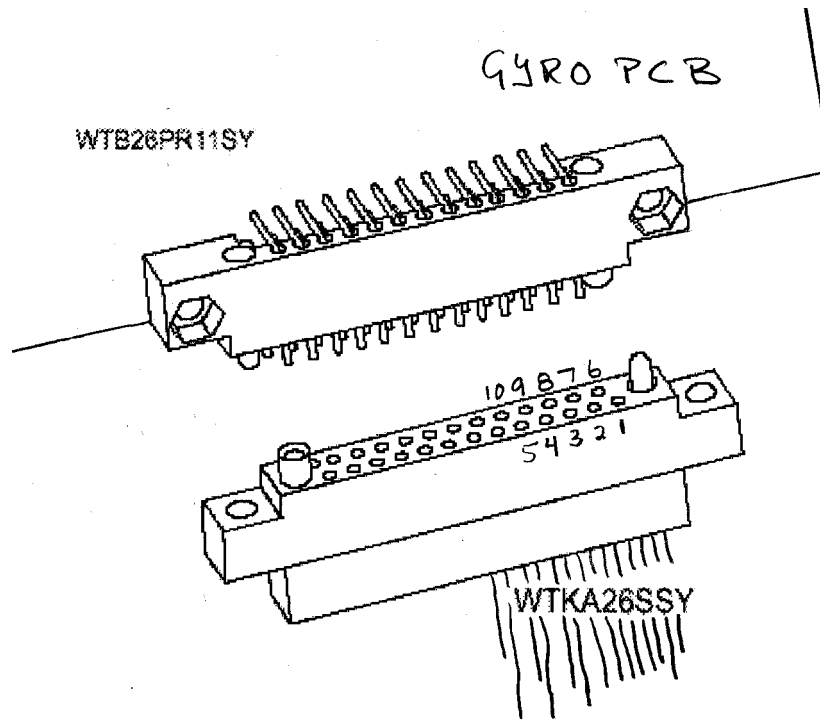

Line assignments for **gyro connector P3** and connections to the mag board are discussed in the mag board documentation (UW and VT).

Gyro connector P4 interfaces to the I/O board. Below is shown the association of lines with pin numbers on this connector.

<u>P4 pin</u>	<u>Line Name</u>	<u>Function</u>
1	Xmag_out	Conditioned mag signal for Bx (UW and VT)
2	Zmag_out	Conditioned mag signal for Bz (UW and VT)
3	GND	Analog ground (reference for all signals)
4	Vref	Reference voltage generated by mag chip (UW and VT)
5	Ygyro_out	Conditioned gyro signal for y-gyro.
6	Ymag_out	Conditioned mag signal for By (UW and VT)
7	N/C	
8	N/C	
9	Zgyro_out	Conditioned gyro signal for z-gyro.
10	Xgyro_out	Conditioned gyro signal for x gyro.

Gyro board connector P2 is a 20-pin connector (Airborn WTB20PR11J) on the side of the board as shown above, and is the interface with the three gyros (x,y, and z) mounted on the end of CEE. It mates with 20-pin connector, Airborn WTKA20SSY which has solder connections for leads which go to the gyros. For UW, these mating connectors are pre-wired, with leads labeled. The geometry of these connectors (identical to connectors P3 and P4), and pin numbering is shown below (26-pin version is shown - all that was available from Airborn documentation).

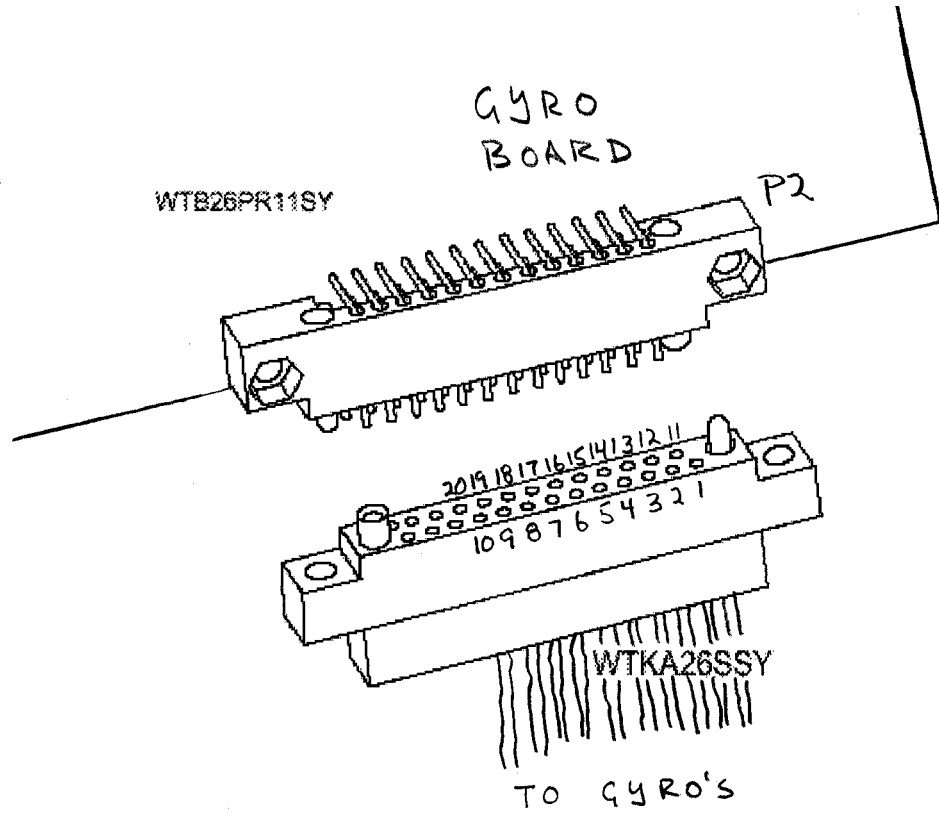

The pin assignments are shown below:

<u>P2 pin</u>	<u>Line Name</u>	<u>Function</u>	<u>P2 pin</u>	<u>Line Name</u>	<u>Function</u>
1	+5V_X	Positive power for Gyro1 ("X")	11	GND	Power ground for Gyro 1 ("X")
2	-5V_X	Negative power for Gyro1 ("X")	12	Xgyro_in	Gyro1 signal
3	Xgnd	Signal ground for Gyro 1("X")	13	1-Wire-X	1-wire temp signal for Gyro 1
4	+5V_Y	Positive power for Gyro2 ("Y")	14	GND	Power ground for Gyro2 ("Y")
5	-5V_Y	Negative power for Gyro2 ("Y")	15	Ygnd	Signal ground for Gyro2 ("Y")
6	Ygyro_in	Gyro 2 signal	16	1-Wire-Y	1-wire temp signal for Gyro2
7	+5V_Z	Positive power for Gyro3 ("Z")	17	GND	Power ground for Gyro3 ("Z")
8	-5V_Z	Negative power for Gyro3 ("Z")	18	Zgyro_in	Gyro3 signal
9	Zgnd	Signal ground for Gyro3 ("Z")	19	1-Wire-Z	1-wire temp signal for Gyro3
10	N/C		20	N/C	

Note that *none* of these lines should be "daisy-chained" among gyros (e.g. connecting +5V_X from pin 1 to positive inputs of all gyros is forbidden), because the power lines are separately filtered to avoid cross-talk among gyros, and the signal ground *output* lines (pins 3,9,15) are generated separately by each gyro (reference for differential amplification on the gyro board). Note also that all lines going to each gyro unit are terminated at neighboring pins of P2 (e.g. pins 1,2,3,11,12,13 for Gyro X), to minimize tangling.

In the board design, the three orthogonal gyro directions and associated circuitry are designated "X", "Y", and "Z". However, any gyro can be connected to any set of lines, as long as you keep track of which *output* lines (Xgyro_out, Ygyro_out, Zgyro_out, to I/O board via gyro connector P4) are associated with which gyro.

The gyros are BEI Systron Donner Model QRS11. The gyro I/O is via a 10-pin receptacle on the top of each gyro. Only 5 of these pins are actually used for this application: Power inputs "+Vdc" (+5V, gyro pin 3), "-Vdc" (-5V, gyro pin 9), "Power Ground" (gyro pin 4); signal outputs "Signal Ground" (gyro pin 8) and "Rate Output" (gyro pin 7). The specification sheet instructs that leads be directly soldered to the I/O pins on a gyro, and that a connector **NOT** be used for flight application. The below figures from the specification sheet show the geometry and table of pin functions:

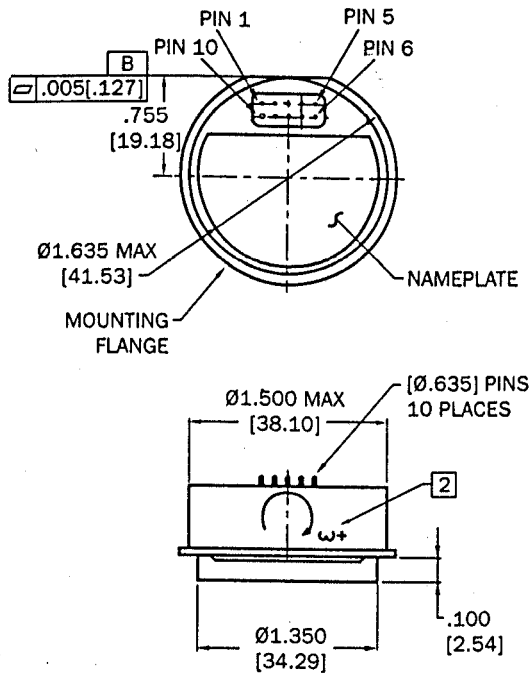

QRS11-XXXXX-XXX	
Solder Pin	Assignment
1	No Connection, Leave Open
2	Self Test Input ⁴
3	+Vdc Input
4	Power Ground
5	BIT Output ⁵
6	No Connection, Leave Open
7	Rate Output
8	Signal Ground
9	-Vdc Input
10	Case Ground

In addition, a Dallas Semiconductor DS18B20 temperature sensor (TO-92 transistor package) must be cemented to each gyro for sensing its temperature. The figure below shows the pinout of this sensor:

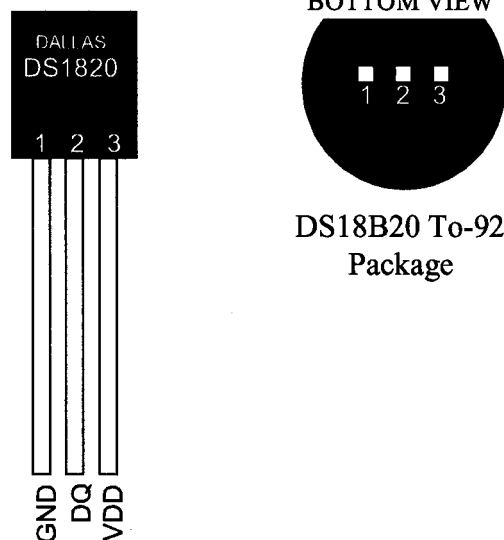

The DS18B20 requires +5V for power (Vdd, pin 3). Power at Vdd and GND can be supplied via wires running from the +5V and GND input pins on the gyro. The 1-Wire-bus lead for that gyro can be soldered to the "DQ" pin (pin 2) of the DS18B20. Make sure to strain-relieve that wire, and it is suggested that heat-shrink be used to cover the solder joints to minimize possibility of a short. (It might also be a good idea to place a small piece of kapton tape on the gyro, underneath the sensor pins' solder joints.)

Gyro connector P1 (122-pin, Airborn WGA122PR9SY-D01) is the interface between the board and CEE backplane. The backplane pins used by the gyro board are listed below:

<u>P1 pin</u>	<u>Line Name</u>	<u>Function</u>
11	1-Wire	1-Wire data line. Used for gyro and mag chip temp sensors (DS18B20).
34,74,115	Bus +	Bus positive. Used for powering mag board Set and Reset (UW & VT)
35,75	GND	Bus power ground.
38,78,119	+12V	Power for mag chip (UW & VT).
39,79,120	-5V	Negative power for gyros, gyro-board circuitry.
40,80,121	+5V	Positive power for gyros, gyro-board circuitry, and gyro temp sensors.
47	Pwr_gyro	Logic input. LO: gyro board power on; HI: gyro board power off.
56	LM_gyro	Analog output. Monitor gyro & mag currents (see below).
70	IRQ_OVERCUR	Logic output. Line pulled LO if gyro & mag currents out-of-bounds.
63	Set	Logic input. Pull HI to "set" mag chip (UW & VT - see mag doc.)
64	Reset	Logic input. Pull HI to "reset" mag chip (UW & VT - see mag doc.)

Signal conditioning

The gyro board provides signal conditioning for both the magnetometer signals (UW and VT) and gyro signals. Magnetometer signal conditioning is described in mag board documentation. The gyros produce voltages [between gyro output pin "Rate Output" (called Agyro_in on the gyro board), and gyro output pin "Signal Ground" (called Agnd on the gyro board), where A is "X", "Y", or "Z"] proportional to the rate of rotation about their respective axes. These signals are differentially buffered (Gain=1) and filtered (single-pole, low-pass at $\tau=0.022$ sec, 3-dB frequency $f=7.2$ Hz). The buffered output signals Xgyro_out, Ygyro_out, and Zgyro_out, referenced to board GND, are sent to the I/O board via gyro board connector P4 as described above. Note that the buffer chip (U2 on the gyro board) is powered by +5V and -5V, so the analog outputs will be restricted to this range of voltages (-5V to +5V). As recommended in the gyro spec sheet, the +5V and -5V power leads to each gyro are filtered to eliminate noise and cross talk. The filters are low-pass filters using 1Ω resistors and 100uF tantalum capacitors (time constant 0.1 msec).

Temperature Sensors

As described above, DS18B20 temperature sensors should be cemented to each gyro, with leads connected to power (+5V), ground, and the 1-Wire data line. The data signals for these sensors are routed to the 1-wire bus on the backplane (gyro connector P1 pin 11), along with the temperature signal from the magnetometer board (UW and VT).

Overcurrent Sensing

The gyro spec sheet indicates that the current of each gyro is $\leq 70\text{mA}$ at +5V and -5V power input, i.e., a total current of $\leq 210\text{ mA}$ at each voltage. For the magnetometers used by UW and VT, the magnetometer spec sheet indicates the current at +12V will be $\leq 20\text{mA}$. To detect potential failure of gyros (and/or magnetometer), the gyro board currents at +5V, -5V and +12V are sensed on the gyro board. Circuitry onboard generates an analog signal $V_{\text{LM_GYRO}}$ (Volts) = $5 * [I_{+12}(\text{Amps}) + I_{+5}(\text{Amps}) + I_{-5}(\text{Amps})]$, which is routed to backplane pin 56 (LM_GYRO). At maximum currents according to specifications (total current 0.44Amps), this signal should be 2.2V. Also onboard, $V_{\text{LM_GYRO}}$ is compared to a fixed reference voltage, $V_{\text{ref}}=3.27\text{V}$. When $V_{\text{LM_GYRO}}$ exceeds V_{ref} , backplane pin 70 (IRQ_OVERCUR) is pulled LO by NPN output transistor Q2. [Normally Q2's output is high impedance.] This signals that the net current exceeds 0.65 Amps (about 50% higher than maximum specified current on each gyro and magnetometer), indicating a probable fault of gyros or magnetometer. When IRQ_OVERCUR is pulled LO, it is expected that the system CPU will detect this, poll all analog current-sense signals, and determine via the signal at LM_GYRO that the gyro board has a fault. Activating backplane pin 47 (PWR_GYRO) HI will cut off current to the board at all three voltages (+5V, -5V, +12V), to resolve the fault. Of course, PWR_GYRO should normally be held LO to enable the gyro board to function normally.

Remaining work required on Gyro Board prior to flight

- 1) The gyro board utilizes several parts with TO-92 or similar 3-lead transistor packages. The pads for these parts are in-line (not offset). Unfortunately, the boards were assembled with rather long leads on these parts, which could easily bend under vibration during launch. All such parts on the gyro board should be "stiffened" against this possibility by applying Dow Corning DC6-1104 sealant (space qualified sealant) around the leads between the base of each package and the board. It is permissible to bend over selected parts to better affix parts to the board, as long as there is no interference with surrounding parts.
- 2) Affix a DS18B20 1-Wire temperature sensor (TO-92 package) to each gyro, cementing the flat face of the sensor to the gyro case with a space-qualified, thermally-conducting cement. Position each sensor, so that +5V and GND leads from gyro pins to the sensor will not be too long. It is advised that separate multistrand wires be used to connect DS18B20 leads and gyro pins (i.e., DS18B20 leads *not* be directly soldered onto gyro pins), to avoid stresses.
- 3) Determine correct lengths for the wires (on the connector mating with gyro board receptacle P2) between gyro board connector P2 and each gyro and cut leads. Solder respective leads (see above for pinouts) directly onto pins of the gyro. Strain-relieve the 1-wire bus lead going to each gyro, and solder to the "DQ" pin (middle pin) of its DS18B20 temperature sensor. It is advised to use heat shrink tubing to cover exposed solder joints and exposed leads/pins following soldering.
- 4) Determine correct lengths for the wires (on the connector mating with gyro board receptacle P4) running from gyro board connector P4 to the I/O board top connector, and cut leads. Attach these leads to the I/O board top connector.

[Instructions on gyro board - to - mag board connections are provided in the mag board documentation.]

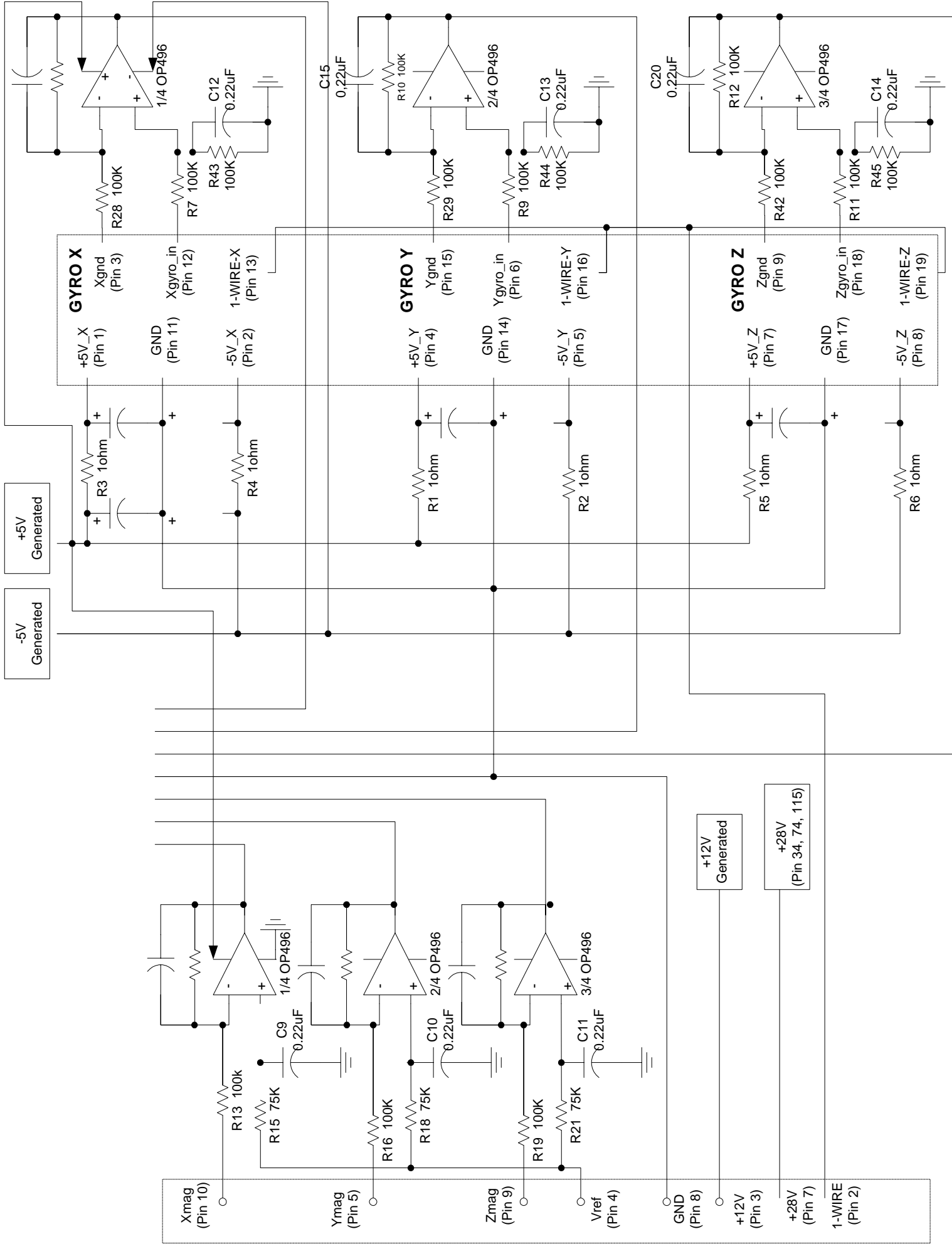

GYRO BOARD COMPONENTS - Page 1/2

		<u>Mfg - part number</u>	<u>Package</u>	<u>Vendor</u>	<u>Packing Slip</u>
<u>Semiconductors</u>					
U1,U2,U3	Quad R-R Op amp	ADI OP496GP	8-DIP	Rochester El.	RE01-2
U4,U5	Current sensor	Maxim MAX471EPA	8-DIP	Maxim	MX01-1
M1,M2	P-Ch Mosfet	IRF IRFD9024	4-DIP	Digikey	DK01-8
M3	N-Ch Mosfet	IRF IRLD024	4-DIP	Digikey	DK01-8
M4,M5	P-Ch Mosfet	Zetex ZVP4105A	TO-92	Digikey	DK01-8
M6,M7,M8	N-Ch Mosfet	Zetex ZVN4306A	TO-92	Digikey	DK01-2
Q1-Q4	NPN transistor	Fairchild 2N4401	TO-92	Digikey	DK01-8
Q5	PNP transistor	Fairchild 2N4403	TO-92	Digikey	DK01-8
<u>Resistors</u>					
R1-R6	1 Ω , 1/8W, 5%, cf	Yageo CFR-12JB-1R0	axial	Digikey	DK01-8
R7-R13,R16, R19,R28,R29, R43-R45,	100k, 1/8W, 1% mf	Xicon 270-100K	axial	Mouser	ME01-1
R14,R17,R20,	332k, 1/8W, 1% mf	Xicon 270-332K	axial	Mouser	ME01-5
R15,R18,R21	75k, 1/8W, 1% mf	Xicon 270-75K	axial	Mouser	ME01-5
R22-R27	49.9k, 1/8W, 1% mf	Xicon 270-49.9K	axial	Mouser	ME01-1
R30,R31,R35	1k, 1/8W, 1% mf	Xicon 270-1K	axial	Mouser	ME01-1
R32,R36-38, R40,R46,R52	10k, 1/8W, 1% mf	Xicon 270-10K	axial	Mouser	ME01-1
R33	.05 Ω , 1/4W, 5%	Ohmite 603HR050	axial	Mouser	ME01-5
R34	100 Ω , 1/8W, 1% mf	Xicon 270-100	axial	Mouser	ME01-5
R39	165k, 1/8W, 1% mf	Xicon 270-165K	axial	Mouser	ME01-5
R41,R47,R48, R50,R51	5.1k, 1/8W, 1% mf	Xicon 270-5.1K	axial	Mouser	ME01-5
R53	200 Ω , 1/4W, 1% mf	Xicon 271-200	axial	Mouser	ME01-5

GYRO BOARD COMPONENTS - Page 2/2

		<u>Mfg - part number</u>	<u>Package</u>	<u>Vendor</u>	<u>Packing Slip</u>
<u>Capacitors</u>					
C1-C8	100uF, 10V, tantalum	AVX TPSD107M010R0100	s.m.	Allied	AL01-3
C9-C15,C19-20	0.22uF, 50V, mf	Panasonic ECQ-V1H224JL	radial	Digikey	DK01-8
C16-18	0.1uF, 50V, cer. X7R	BC Comp. K104K15X7RF5TL2	radial	Digikey	DK01-8
<u>Other</u>					
P1	122-pin connector	Airborn WGA122PR9SY-D01		Airborn	
P2	20-pin connector	Airborn WTB20PR11J		Airborn	
P3,P4	10-pin connector	Airborn WTB10PR11SY		Airborn	