

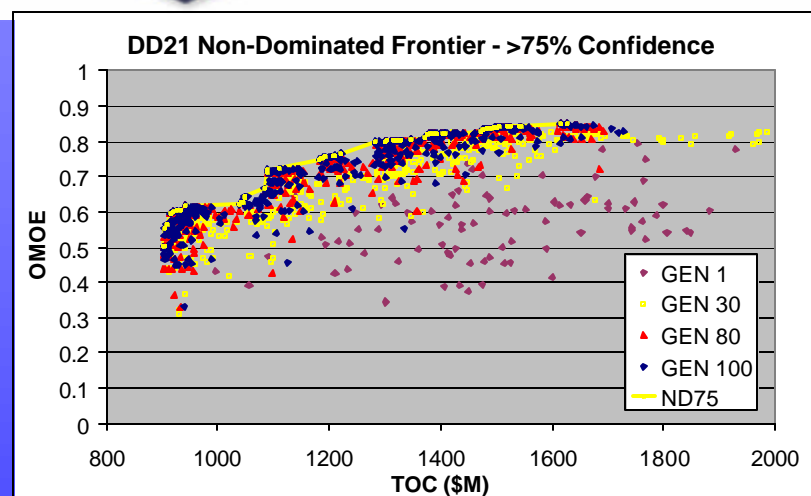

Center for Innovation in Ship Design



Ship Concept Exploration and Development
Using Multi-Objective and Multi-Disciplinary Optimization

AOE Advisory Board
October 15, 2004



Perspectives

- Education
- Research
- Application



AOE 4065 and 4066

Undergraduate Ship Design

- 2 semester capstone course
- Recent designs
 - Unmanned Combat Air Vehicle Carrier (CUVX) - 2003
 - Agile Surface Combatant (ASC) - 2004
 - Littoral Warfare Submarine (LWSS) – 2002,2005
 - Advanced Logistics Delivery System Carrier (ALDV) - 2005
- Fall – Concept Exploration
- Spring – Concept Development
- Lisnyk Ship Design Competition

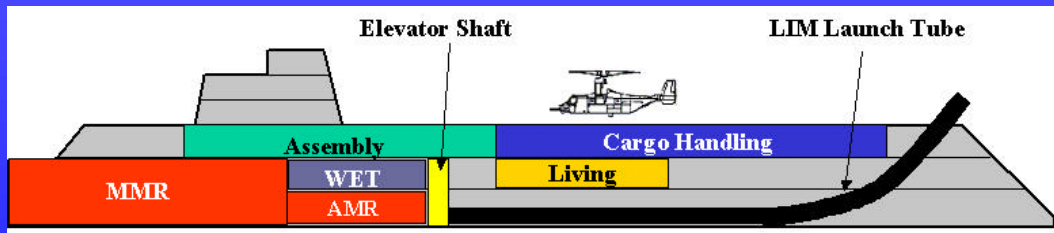
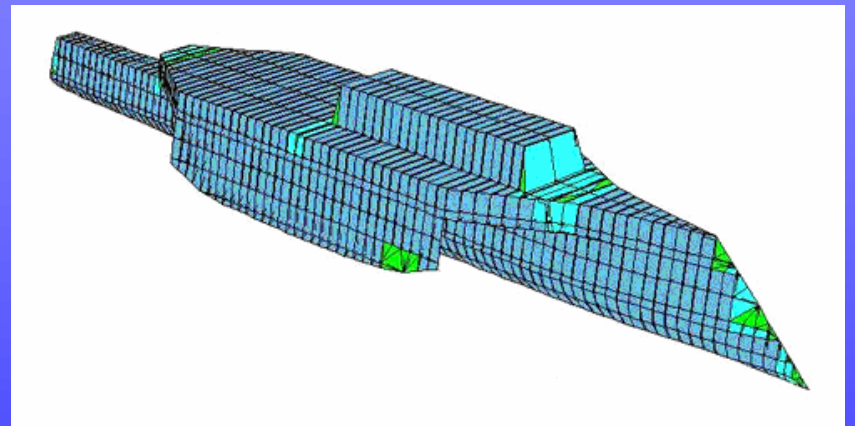
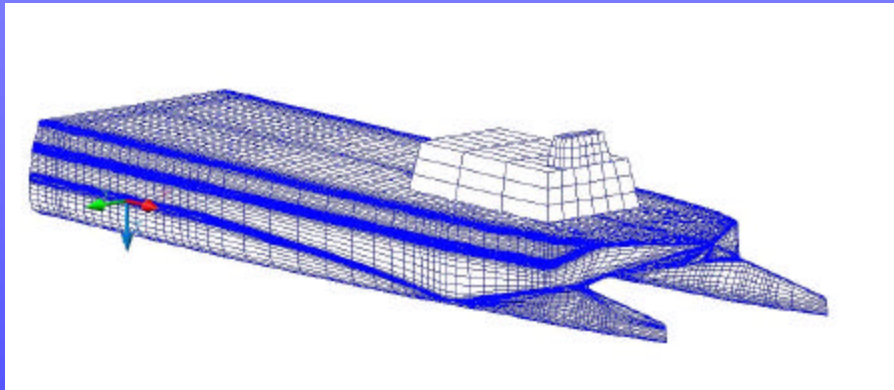
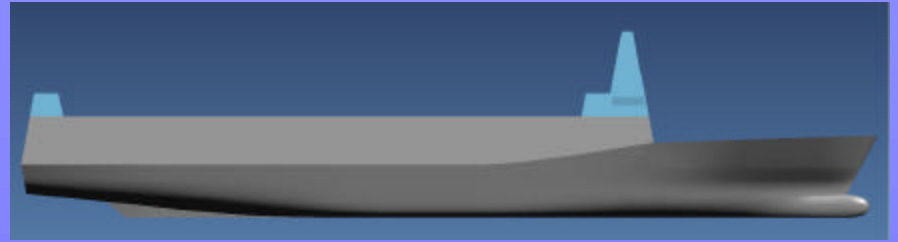
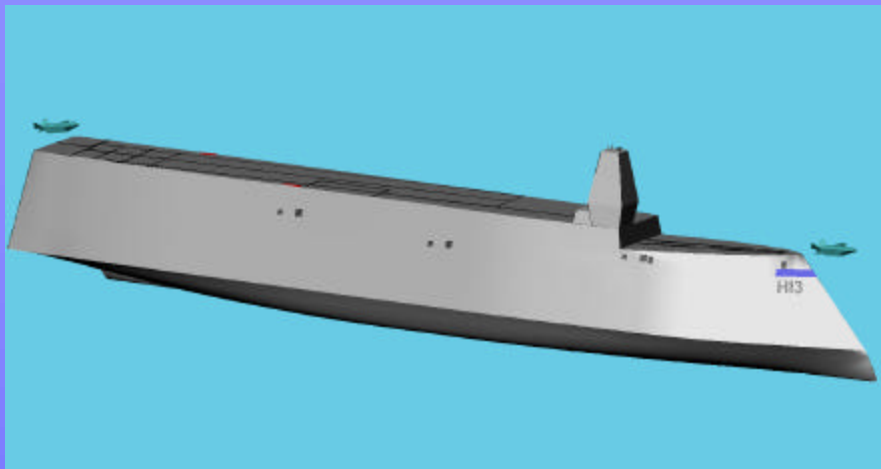



Lisnyk Ship Design Competition



- Started as a SNAME local section competition in the mid-1980s (Washington DC area)
- Early 1990s – began limited international participation
- SNAME national organization took over the competition in 1995 and immediately made it an international competition with significant publicity
- ASNE became a joint sponsor with SNAME in 1998
- Annual, student teams propose original Owner's Requirements, max 6 students/team
- VT first US school to win the competition since the 1995 change in sponsorship and scope. Winners since 1995:
 - 1995 - Newcastle upon Tyne (VT was #2)
 - 1996 - Norwegian University of Science and Technology
 - 1997 - Newcastle upon Tyne (UMich was #3)
 - 1998 - Norwegian University of Science and Technology (UMich was #3)
 - 1999 - Newcastle upon Tyne
 - 2000 - Newcastle upon Tyne (VT #2 and #3)
 - 2001 - Newcastle upon Tyne (VT was #2, UMich #3)
 - 2002 - Norwegian University of Science and Technology (VT was #3)
 - 2003 - Virginia Tech #1 - CUVX
 - 2004 – Virginia Tech #1 – ASC Trimaran



Design Research Objectives

- A consistent format and methodology for making affordable multi-objective (3) acquisition decisions and trade-offs in non-dominated design space
- Practical and quantitative methods for measuring mission effectiveness
- Practical and quantitative methods for measuring risk
- An efficient and robust method to search design space for optimal concepts with a range of probabilities of success - uncertainty
- An effective framework for transitioning and refining concept development in a multidisciplinary design optimization (MDO).
- Use the results of first-principle analysis codes at earlier stages of design.



Scope

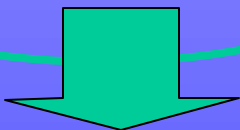

Exploratory Design

Mission or Market Analysis

Technology Development

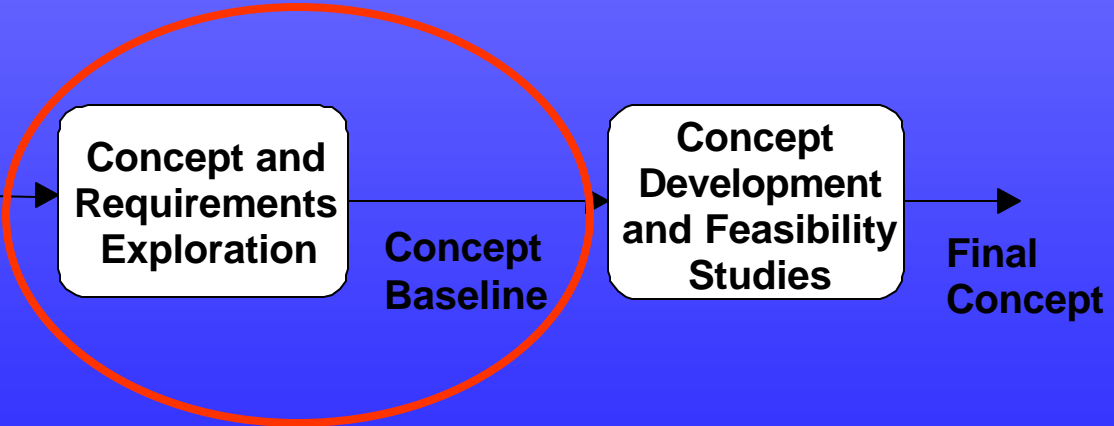



CONCEPT
EXPLORATION

CONCEPT
DEVELOPMENT

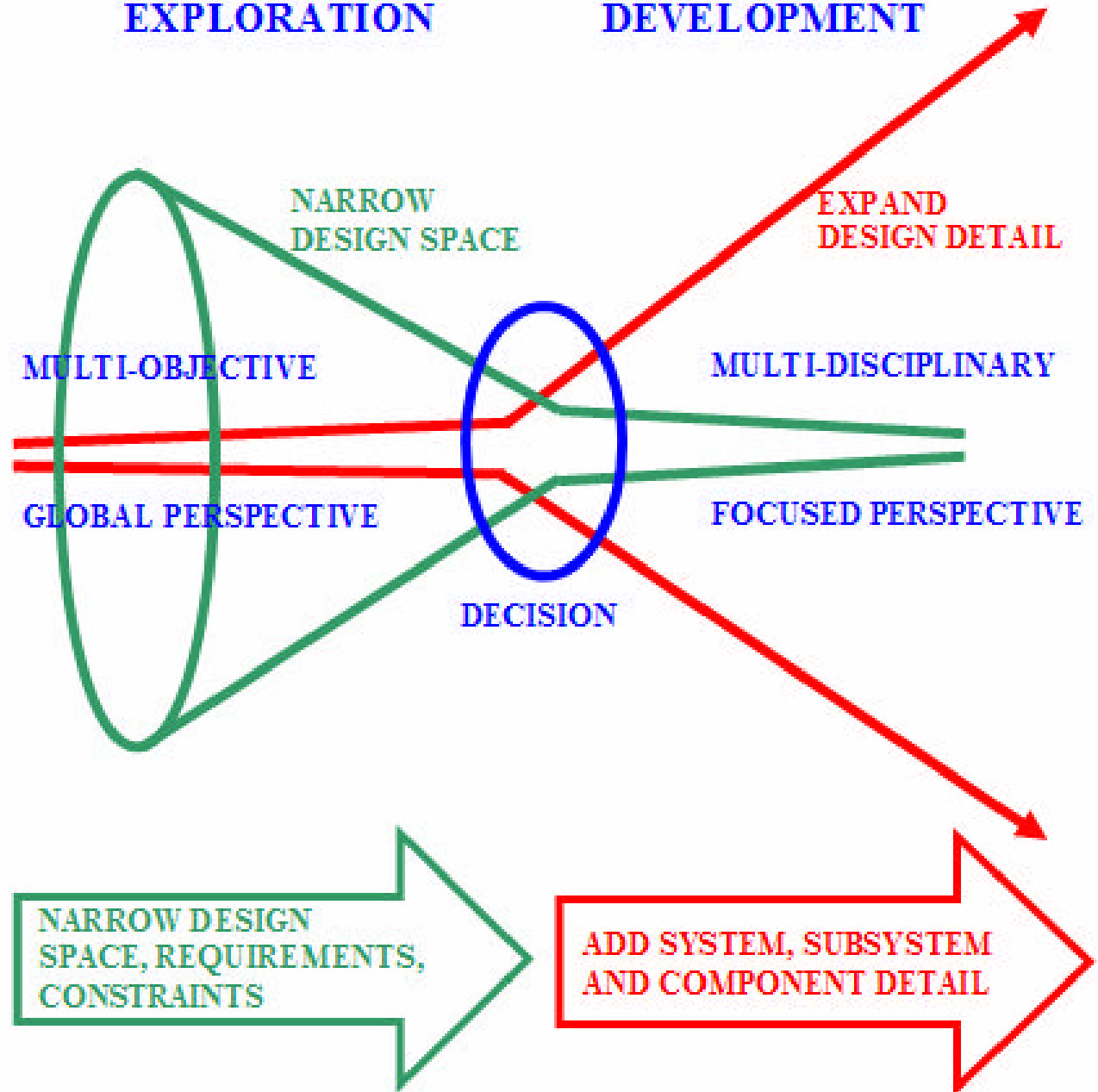

Design Strategy



Concept Exploration Process

- Define Mission – CONOPs, POE, ROCs, scenarios
- Technologies/Trades – hullform, power and propulsion, combat systems, automation
- Standards and Specs
- Design Space
- Metrics – Effectiveness, Cost, Risk
- Build ship synthesis model, select modules
- Multi-objective Optimization (Hands off!)
 - No magic!
 - No imagination!
 - Success depends on “Preparation”!
- Select baseline design(s) from non-dominated frontier



CUVX Mission Need

- **Current assets for ISR and First Day of War time-sensitive warfighting:**
 - Land and carrier-based aircraft and UAV's
 - Cruise missiles from US submarines and surface ships
 - Space-based and long-range aircraft assets
- **These assets:**
 - Are costly
 - Put many personnel in harms way
 - Have limited numbers for seaborne positioning and rapid employment
- **The Unmanned Combat Air Vehicle (UCAV-N) is a transformational technology with the potential to address these problems**
- **UCAV-N requires a support platform. Material alternatives include:**
 - CVNs support manned and unmanned aircraft
 - Surface ship specifically designed or modified to support UAVs and UCAVs

Alternatives include:

 - Convert existing LHD or LHA class ships
 - Design and build a modified-repeat LHD or LPD-17
 - Design and build an entirely new class of UCAV carrier (CUVX)



UCAV (VT UCAV-N)

- VT UCAV-N
 - ISR
 - SEAD
 - Strike
 - HARM (high-speed anti-radiation missile)
 - AIM-120 AMRAAM Slammer
 - JDAM (Joint Direct Attack Munition)
- Dimensions (folded):
 - **9.2 m wingspan x 9.7 m long x 4.4 m high**
- Dimensions (unfolded):
 - **13.7 m wingspan x 9.7 m long x 3.6 m high**
- Weight: **12 Mtons**

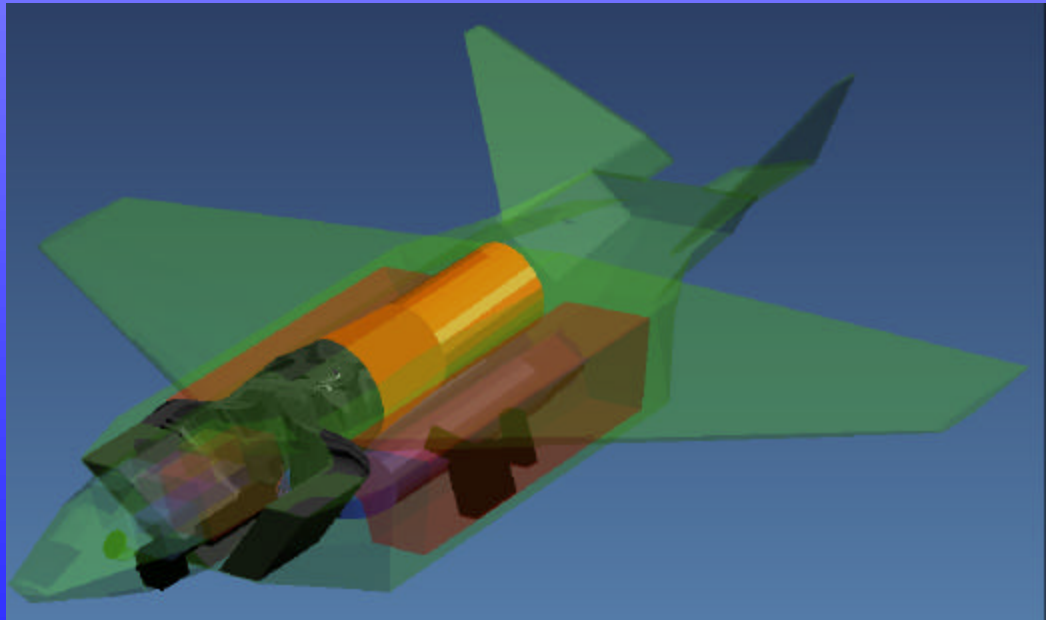
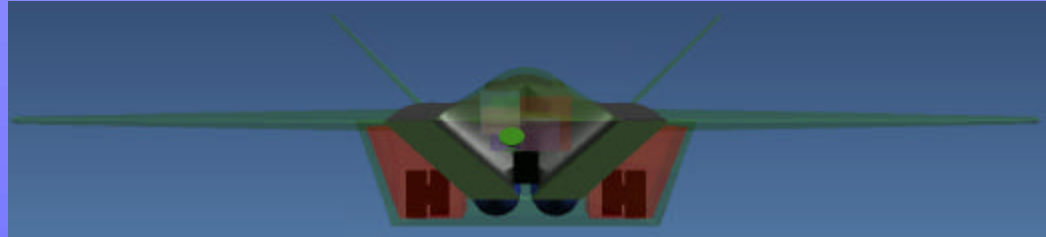



Acquisition Decision (ADM)

- Authorized Concept Exploration of two CUVX material alternatives
 - Modified-repeat LPD-17
 - New CUVX ship design
- Guidance
 - Support 20-30 UCAVs and UAVs, providing for takeoff and landing, fueling, maintenance, weapons load-out, planning and control
 - Provide own defense with significant dependence on passive survivability and stealth
 - Minimize life cycle cost through the application of producibility enhancements and manning reduction
 - Minimize personnel vulnerability in combat through automation
 - Average follow-ship acquisition cost shall not exceed \$500M (\$FY2005), not including aircraft.
 - 30 ships, IOC 2012
 - CUVX concepts will be explored in parallel with UCAV-N Concept Exploration and development using a Total Ship Systems Engineering approach.



CUVX CONOPS

- Operate in littoral areas, close-in, depend on stealth, with high endurance, minimum external support, and low manning
- Providing for aircraft takeoff and landing, fueling, maintenance, weapons load-out, planning and control
 - UAVs - surface, subsurface, shore, and deep inland surveillance, reconnaissance and electronic warfare\
 - LAMPS – Anti-Submarine Warfare (ASW) and Anti-Surface Ship Warfare (ASUW) defense
 - UCAVS - initial/early conflict Suppression of Enemy Air Defenses (SEAD), Strike and mining
- Operate independently or in conjunction with small Surface Attack Groups
- Capable of performing unobtrusive peacetime presence missions in an area of hostility, and immediately respond to escalating crisis and regional conflict
- Likely to be forward deployed in peacetime, conducting extended cruises to sensitive littoral regions
- Provide own defense with significant dependence on passive survivability and stealth
- Post-conflict - continue to monitor all threats
- First to arrive and last to leave the conflict area



CUVX Mission Types

- Pre-conflict
 - Intelligence, Surveillance and Reconnaissance (ISR)
- Conflict
 - Continue ISR
 - SEAD
 - Mining
 - Pre-position and support UCAVs for time-sensitive air and missile strikes (HARM and JDAM)
 - SPECOPS
 - ASW / ASuW / with LAMPS
- Post-conflict
 - Continue ISR



Mission Scenarios (ASC)

Day	Mission scenario for MCM
1-21	Small ASC squadron transit from CONUS
21-24	Port call, replenish and load MCM modules
25-30	Conduct mine hunting operations
29	Conduct ASuW defense against small boat threat
31-38	Repairs/Port Call
39	Engage submarine threat for self-defense
41	Engage air threat for self defense
39-43	Conduct mine hunting operations
43	Unrep
44-59	Join CSG/ESG, continue mine hunting and mapping
60+	Port call or restricted availability



Effectiveness Metric

- Inputs affecting overall mission effectiveness metric:
 - defense policy and goals
 - threat
 - existing force structure
 - mission need
 - mission scenarios
 - modeling and simulation or war gaming results
 - expert opinion
- Master war-gaming model?
 - Many runs / regression
 - Series of probabilistic scenarios
 - Accuracy depends on modeling the detailed interactions of a complex human and physical system and its response to a broad range of quantitative and qualitative variables and conditions including ship MOPs
- This extensive modeling capability does not yet exist for practical applications! – Alternative?



OMOE and OMOR Development Process

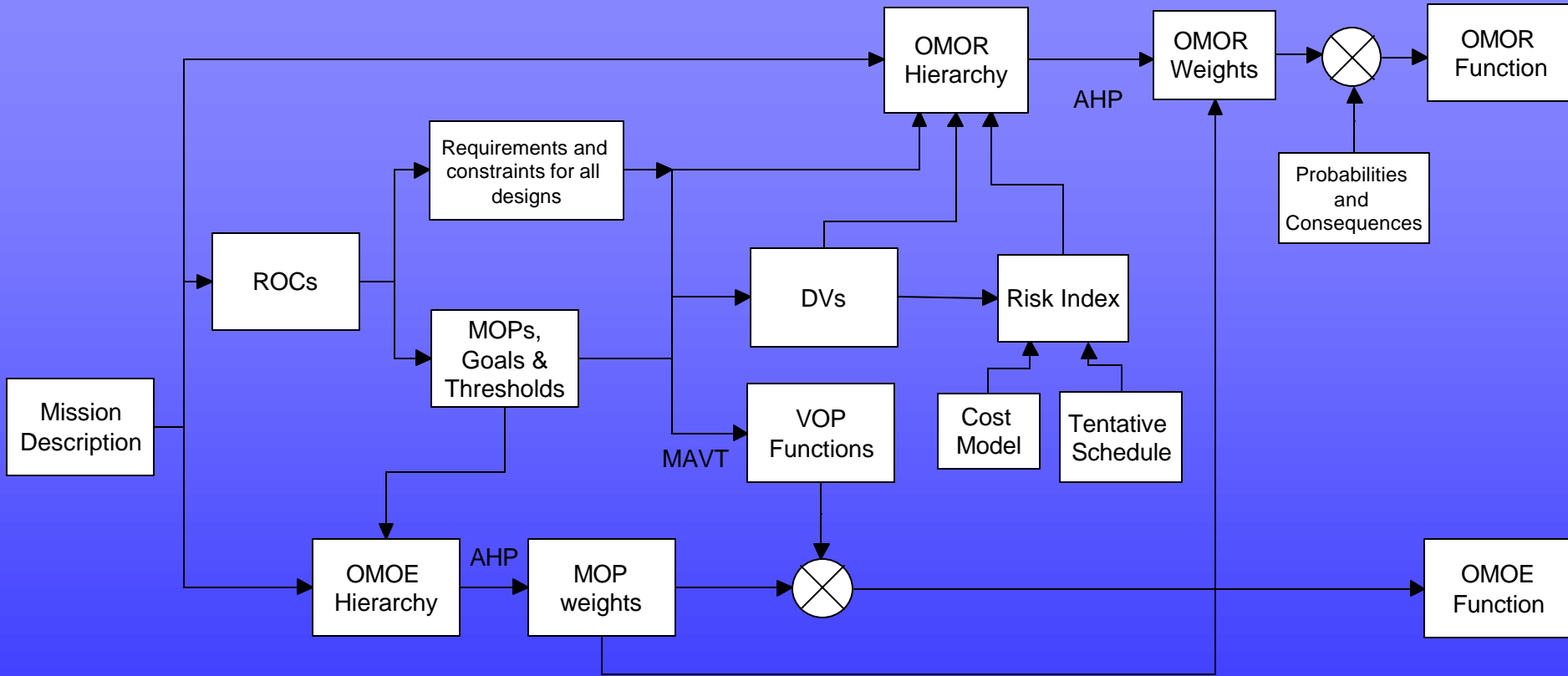

$$OMOE = g[VOP_i(MOP_i)] = \sum_i w_i VOP_i(MOP_i)$$

Analytical Hierarchy Process (Saaty, 1996) +
 Multi-Attribute Utility Theory (Keeney and Raiffa 1976) =
 Multi-Attribute Value (MAV) function (Belton, 1986) or Weighted Utility Function



ROCs > MOPs > G & Ts > DVs

ROC	Primary MOP or Constraint	Threshold or Constraint	Goal	Related DV
MOB 1 - Steam to design capacity in most fuel efficient manner	MOP10 – Sprint range MOP11 – Endurance range MOP13 – Sprint speed	1000 nm 3500 nm 40 knots	1500 nm 4500 nm 50 knots	DV1 – Hull form, DV2 - Displacement DV1 – Hull form, DV2 - Displacement DV 7 – Propulsion System alternative
MOB 3 - Prevent and control damage	MOP16 – Structural vulnerability MOP17 – Personnel vulnerability MOP18 – Damage stability MOP20 – RCS MOP21 – Acoustic signature MOP22 – IR Signature MOP23 – Magnetic signature	Aluminum hull 100 Catamaran 7000 m3 Mechanical LM2500+ Aluminum No Degaussing	Steel hull 50 Trimaran 2000 m3 IPS ICR Steel Degaussing	DV4 – Hull material type DV9 – Manning and automation factor DV1 – Hull form DV3 – Deckhouse volume DV7 – Propulsion System alternative DV7 – Propulsion System alternative DV4 – Hull material type DV8 – Degaussing system
MOB 3.2 - Counter and control NBC contaminants and agents	MOP19 - CBR	No CPS	Full CPS	DV6 – Collective Protection System Type
MOB 5 - Maneuver in formation	Required all designs			
MOB 7 - Perform seamanship, airmanship and navigation tasks (navigate, anchor, mooring, scuttle, life boat/raft capacity, tow/be-towed)	Required all designs			
MOB 10 - Replenish at sea	Required all designs			
MOB 12 - Maintain health and well being of crew	Required all designs			
MOB 13 - Operate and sustain self as a forward deployed unit for an extended period of time during peace and war without shore-based support	MOP11 – Endurance range MOP12 – Provisions	3500 nm 14 days	4500 nm 24 days	DV1 – Hull form DV2 – Displacement DV7 – Propulsion System alternative DV18 – Provisions Duration



CUVX Design Space

Description		Metric	Range	Increments
1	Hull form	type	General monohull, LPD-17, WPTH	3
2	Prismatic coefficient	ND	.6-.8	20
3	Max section coefficient	ND	.9-.99	9
4	Displacement to length ratio	lton/ft ²	50-90	20
5	Beam to Draft Ratio	ND	3-5	20
6	Length to Depth Ratio	ND	6-8	20
7	Aircraft launch deck?	y/n	0,1	2
8	Deckhouse volume ratio	ND	.05-.3	25
9	AAW system	alternative	1,2	2
10	LAMPS helos	#	2,4	2
11	Endurance range	nm	4000,8000,12000	3
12	Stores duration	days	60,90,120	3
13	Propulsion system	alternative	1-14	14
14	Ship manning and automation factor	ND	.5-1.0	5
15	Hull structure type	type	Conventional, ADH	2
16	CPS	extent	None, partial, full	3
17	UAVs	#	5-20	15
18	UCAVs	#	10-30	20
19	Aviation manning and automation factor	ND	.5-1.0	5
20	Ship aircraft fuel	MT/UCAV	30.-60.	10
21	Ship aircraft weapons	MT/UCAV	5.-15.	10



OMOE Hierarchy

Mission Type

MCM

Focused MCM in CSG/ESG or
ASC Squadron Operations

Mission Types

Add

Remove

Rename

Edit

Mission Capability
Categories/Mission
Capabilities

Add

Remove

Rename

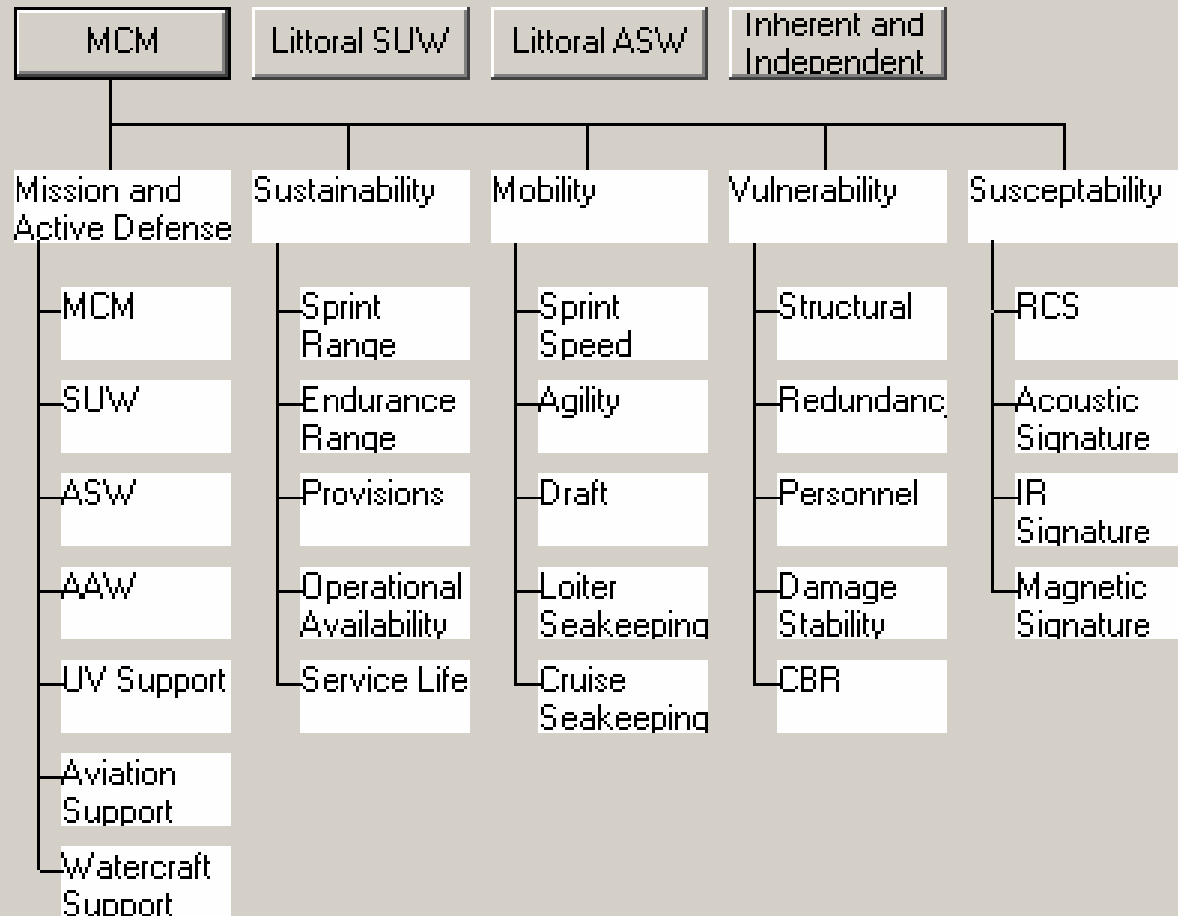



Pairwise Comparison

MOP 1 - Core MCM

Compare the relative importance with respect to: MCM Mission \ Mission and Active Defense \ MCM



MOP 2 - MCM Modules

	MOP 1 - Co	MOP 2 - M	MOP 3 - LA	MOP 4 - Sp	MOP 5 - VT	MOP 6 - C4
MOP 1 - Core MCM		2.0	2.0	2.0	2.0	1.0
MOP 2 - MCM Modules			3.0	3.0	3.0	3.0
MOP 3 - LAMPS				3.0	2.0	1.0
MOP 4 - Spartan					3.0	2.0
MOP 5 - VTUAV						1.0
MOP 6 - C4I						

Incon: 0.04

Questionnaire

Questionnaire

How do the following Mission Types compare?

1 = equal 3 = moderate 5 = strong 7 = very strong 9 = extreme

SAG	<input type="text" value="9"/> <input type="text" value="8"/> <input type="text" value="7"/> <input type="text" value="6"/> <input type="text" value="5"/> <input type="text" value="4"/> <input type="text" value="3"/> <input type="text" value="2"/> <input type="text" value="1"/> <input type="text" value="2"/> <input type="text" value="3"/> <input type="text" value="4"/> <input type="text" value="5"/> <input type="text" value="6"/> <input type="text" value="7"/> <input type="text" value="8"/> <input type="text" value="9"/>	CBG
SAG	<input type="text" value="9"/> <input type="text" value="8"/> <input type="text" value="7"/> <input type="text" value="6"/> <input type="text" value="5"/> <input type="text" value="4"/> <input type="text" value="3"/> <input type="text" value="2"/> <input type="text" value="1"/> <input type="text" value="2"/> <input type="text" value="3"/> <input type="text" value="4"/> <input type="text" value="5"/> <input type="text" value="6"/> <input type="text" value="7"/> <input type="text" value="8"/> <input type="text" value="9"/>	MARG
SAG	<input type="text" value="9"/> <input type="text" value="8"/> <input type="text" value="7"/> <input type="text" value="6"/> <input type="text" value="5"/> <input type="text" value="4"/> <input type="text" value="3"/> <input type="text" value="2"/> <input type="text" value="1"/> <input type="text" value="2"/> <input type="text" value="3"/> <input type="text" value="4"/> <input type="text" value="5"/> <input type="text" value="6"/> <input type="text" value="7"/> <input type="text" value="8"/> <input type="text" value="9"/>	MCG
CBG	<input type="text" value="9"/> <input type="text" value="8"/> <input type="text" value="7"/> <input type="text" value="6"/> <input type="text" value="5"/> <input type="text" value="4"/> <input type="text" value="3"/> <input type="text" value="2"/> <input type="text" value="1"/> <input type="text" value="2"/> <input type="text" value="3"/> <input type="text" value="4"/> <input type="text" value="5"/> <input type="text" value="6"/> <input type="text" value="7"/> <input type="text" value="8"/> <input type="text" value="9"/>	MARG
CBG	<input type="text" value="9"/> <input type="text" value="8"/> <input type="text" value="7"/> <input type="text" value="6"/> <input type="text" value="5"/> <input type="text" value="4"/> <input type="text" value="3"/> <input type="text" value="2"/> <input type="text" value="1"/> <input type="text" value="2"/> <input type="text" value="3"/> <input type="text" value="4"/> <input type="text" value="5"/> <input type="text" value="6"/> <input type="text" value="7"/> <input type="text" value="8"/> <input type="text" value="9"/>	MCG
MARG	<input type="text" value="9"/> <input type="text" value="8"/> <input type="text" value="7"/> <input type="text" value="6"/> <input type="text" value="5"/> <input type="text" value="4"/> <input type="text" value="3"/> <input type="text" value="2"/> <input type="text" value="1"/> <input type="text" value="2"/> <input type="text" value="3"/> <input type="text" value="4"/> <input type="text" value="5"/> <input type="text" value="6"/> <input type="text" value="7"/> <input type="text" value="8"/> <input type="text" value="9"/>	MCG



Weights and Value Functions

Synthesis with respect to:

Goal: Maximize Overall Measure of Effectiveness (OMOE)

Overall Inconsistency = .04

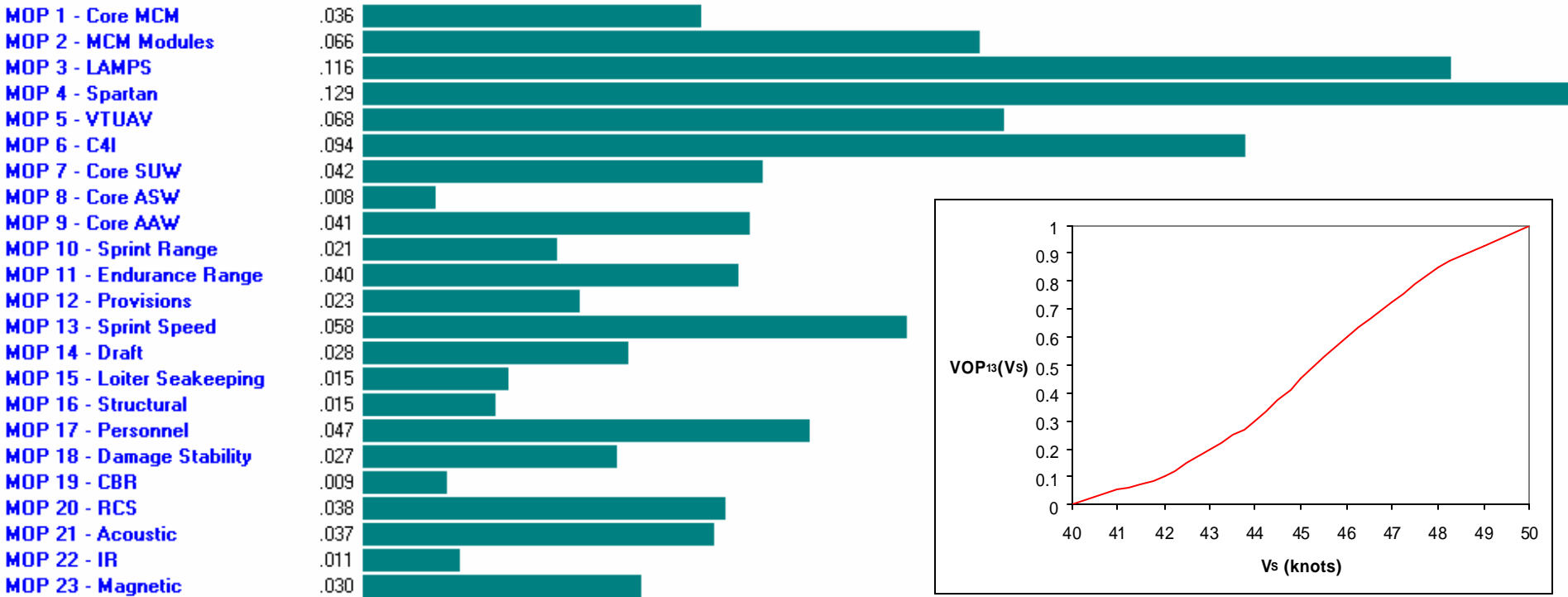

$$OMOE = g[VOP_i(MOP_i)] = \sum_i w_i VOP_i(MOP_i)$$



Concept Exploration Process

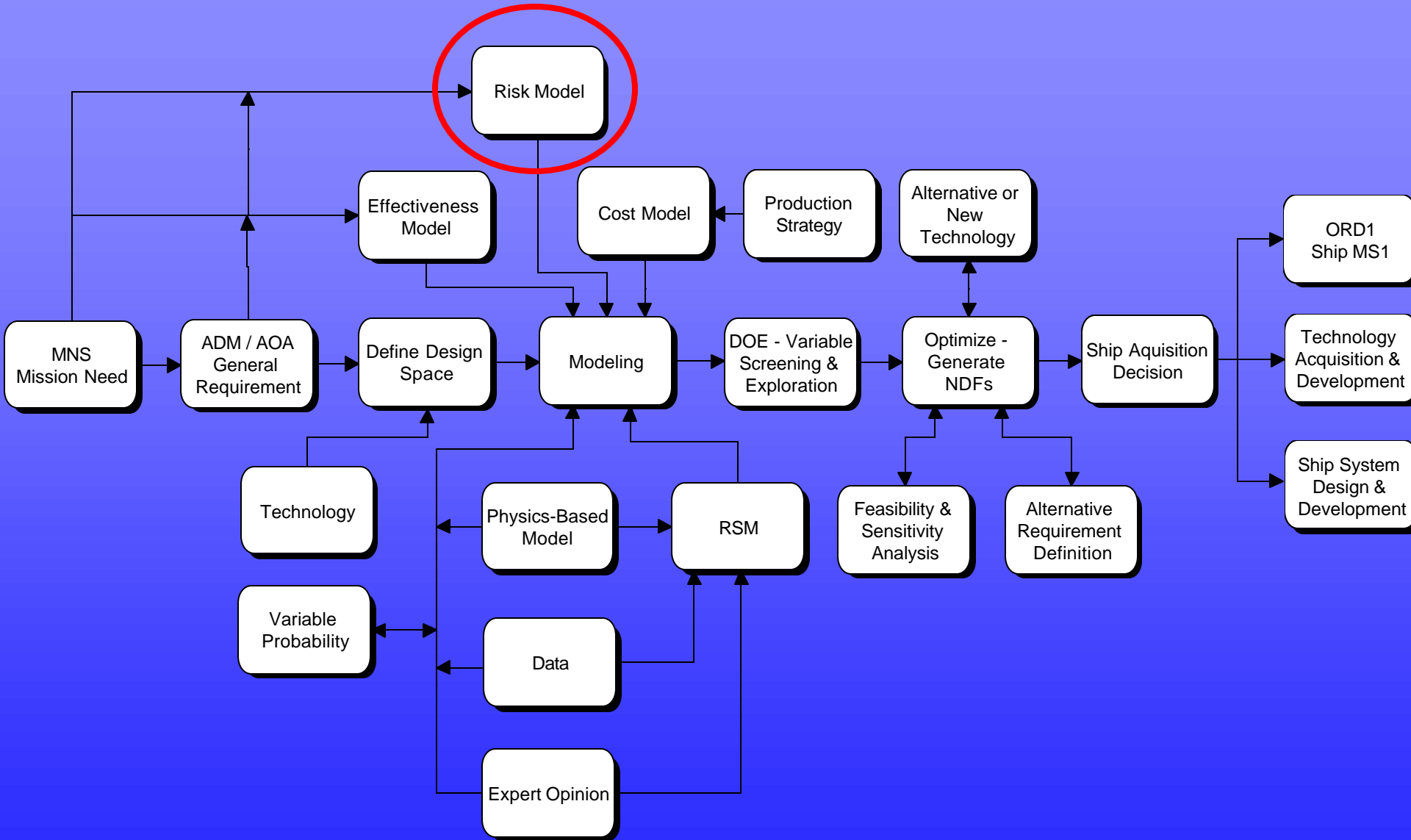



RISK OBJECTIVE ATTRIBUTE (OMOR)

- Understand technology alternatives, ship requirements, schedules and cost estimates. Set effectiveness and performance metrics, goals and thresholds
- Select ship design variables (DVs) and process variables (PVs)
- Identify potential risk areas and events associated with each design and process variable option. Build a risk register (spreadsheet)
- Assign probabilities (P) and consequences (C) to each risk event.
- Calculate a risk rating (R) for each Risk.
- Define the overall measure of risk (OMOR) function

$$OMOR = W_{perf} \sum_i \frac{w_i}{\sum_i w_i} P_i C_i + W_{cost} \sum_j P_j C_j + W_{sched} \sum_k P_k C_k$$



Critical Risk Areas (DoD 5000)

Risk Area	Significant Risks
Threat	<ul style="list-style-type: none"> • Uncertainty in threat accuracy. • Sensitivity of design and technology to threat. • Vulnerability of system to threat and threat countmeasures. • Vulnerability of program to intelligence penetration.
Requirements	<ul style="list-style-type: none"> • Operational requirements not properly established or vaguely stated. • Requirements are not stable.
Design	<ul style="list-style-type: none"> • Status of system development. • Requirement for increased skills. • Reliance on immature technology or "exotic" materials to achieve performance. • Status of software design, coding, and testing.
Test & Evaluation	<ul style="list-style-type: none"> • Test planning not initiated early in program (Phase 0). • Testing does not address the ultimate operating environment. • Test procedures do not address all major performance and suitability specifications. • Test facilities not available to accomplish specific tests, especially system-level tests. • Insufficient time to test thoroughly.
Simulation	<ul style="list-style-type: none"> • M&S are not verified, validated, or accredited for the intended purpose. • Program lacks proper tools and modeling and simulation capability to assess alternatives.
Technology	<ul style="list-style-type: none"> • Success depends on unproved technology for success. • Success depends on achieving advances in state-of-the-art technology. • Technology has not been demonstrated in required operating environment. • Technology relies on complex hardware, software, or integration design.
Logistics	<ul style="list-style-type: none"> • Inadequate supportability late in development or after fielding, resulting in need for engineering changes, increased costs, and/or schedule delays. • Life-cycle costs not accurate because of poor logistics supportability analyses.
Production/ Facilities	<ul style="list-style-type: none"> • Production not sufficiently considered during design. • Inadequate planning for long lead items and vendor support. • Production processes not proven. • Prime contractors do not have adequate plans for managing subcontractors. • Sufficient facilities are not readily available for cost-effective production. • Contract offers no incentive to modernize facilities or reduce cost.
Concurrency	<ul style="list-style-type: none"> • Immature or unproven technologies will not be adequately developed before production. • Concurrency established without clear understanding of risks.
Capability of Developer	<ul style="list-style-type: none"> • Developer has limited experience in specific type of development. • Contractor has poor track record relative to costs and schedule. • Contractor has experienced loss of key personnel. • Prime contractor relies excessively on subcontractors for major development efforts. • Contractor requires significant capitalization to meet program requirements.
Technology Cost/Funding	<ul style="list-style-type: none"> • Realistic cost objectives not established early. • Excessive life-cycle costs due to inadequate treatment of support requirements. • Funding profile is not stable from budget cycle to budget cycle.
Schedule	<ul style="list-style-type: none"> • Schedule does not reflect realistic acquisition planning. • Resources are not available to meet schedule.
Technology Management	<ul style="list-style-type: none"> • Proper mix (experience, skills) of people not assigned to PMO or to contractor team. • Effective risk assessments not performed or results not understood and acted on.



Measure of Consequence

Level	Given the Risk is Realized, What Is the Magnitude of the Impact?		
	Performance, C_i	Schedule, C_k	Cost, C_j
0.1	Minimal or no impact on specific MOP	Minimal or no impact on total ship design or production schedule	Minimal or no impact on total objective cost
0.3	Acceptable with some reduction in margin	Additional resources required; able to meet need dates	<5% increase
0.5	Acceptable with significant reduction in margin	Minor slip in key milestones; not able to meet need date	5-7% increase
0.7	Acceptable; no remaining margin	Major slip in key milestone or critical path impacted	7-10% increase
0.9	Unacceptable	Can't achieve key team or major program milestone	>10% increase



Probability of Risk Event

Likelihood Level	Description
0.1	Remote
0.3	Unlikely
0.5	Likely
0.7	Highly likely
0.9	Near Certain



CUVX Risk Register

SWBS	Risk Type	Risk ID	DV#	DV Description	DV Value	Risk Event E_i	Risk Description	P_i	C_i	R_i
Armament	Performance	1	DV ₁₀	Peripheral VLS	1	Failure of PVLS EDM test	Will require use of VLS or RAM with impact on flight deck and hangar deck area and ops	0.3	0.5	0.15
Hull	Performance	2	DV ₁	WPTH hull form	2	Unable to accurately predict endurance resistance	Will over-predict endurance range.	0.2	0.3	0.06
Propulsion	Performance	3	DV ₂₀	Integrated power system	>5	Development and use of new IPS system	New equipment and systems will have reduced reliability	0.4	0.4	0.16
Hull	Performance	4	DV ₁	WPTH hull form	2	Unable to accurately predict sustained speed resistance	Will over-predict sustained speed.	0.2	0.5	0.1
Hull	Performance	5	DV ₁	WPTH hull form	2	Unable to accurately predict WPTH seakeeping performance	Seakeeping performance will not be acceptable	0.5	0.5	0.25
Hull	Performance	6	DV ₁	WPTH hull form	2	Unable to accurately predict WPTH extreme motions and stability	Damaged stability performance will not be acceptable	0.7	0.7	0.49
Hull	Performance	7	DV ₈	Separate launch deck	1	Concept doesn't work preventing simultaneous launch and recovery for SEAD mission	Unforeseen problems with dedicated launch deck (launch, fuel, weapons)	0.4	0.8	0.32
Hull	Performance	8	DV ₈	Separate launch deck	1	Concept doesn't work preventing simultaneous launch and recovery for Strike mission	Unforeseen problems with dedicated launch deck (launch, fuel, weapons)	0.4	0.9	0.36
Propulsion	Schedule	9	DV ₂₀	Integrated power system	>5	Development and integration of new IPS system will be behind schedule	Unexpected problems with new equipment and systems	0.3	0.3	0.09



Concept Exploration Process

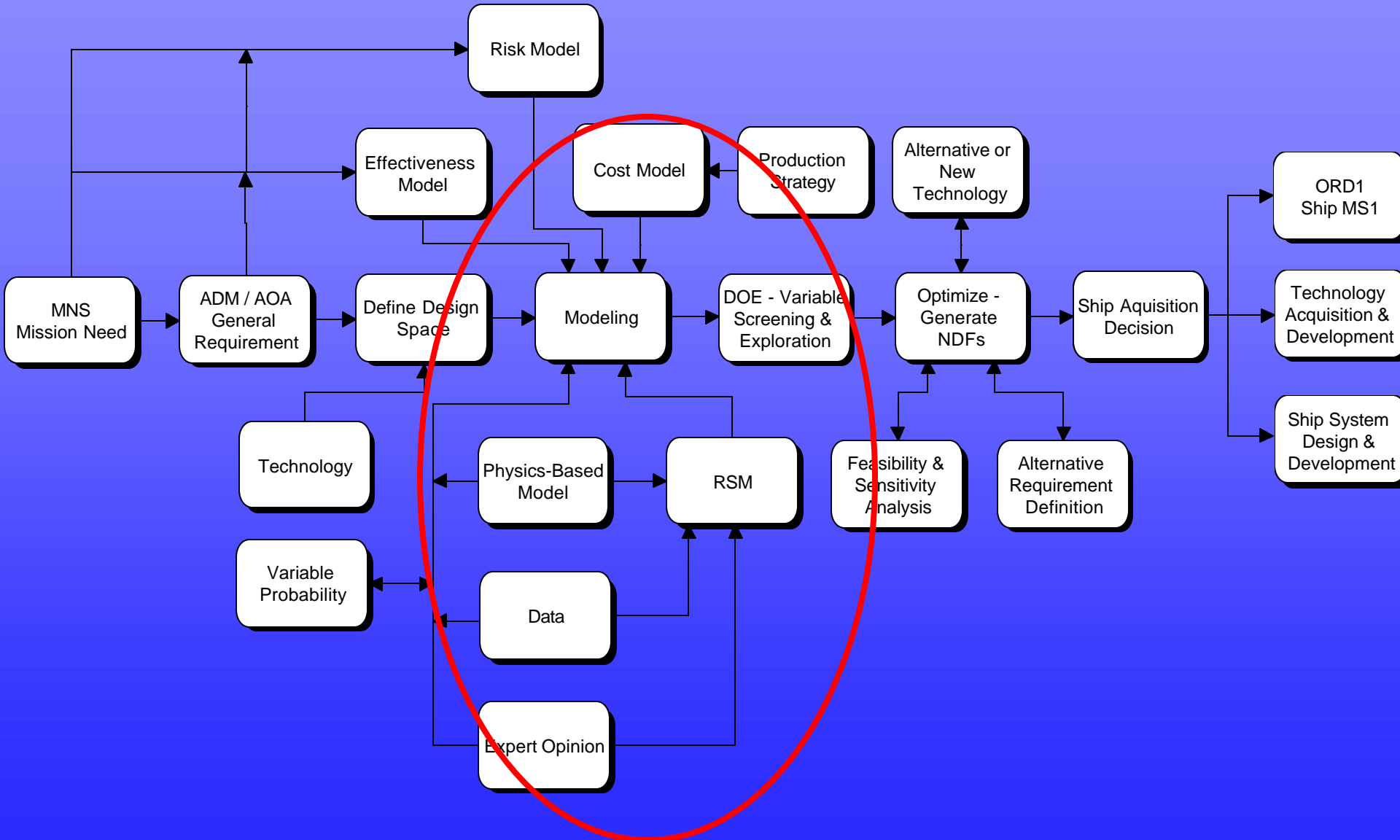

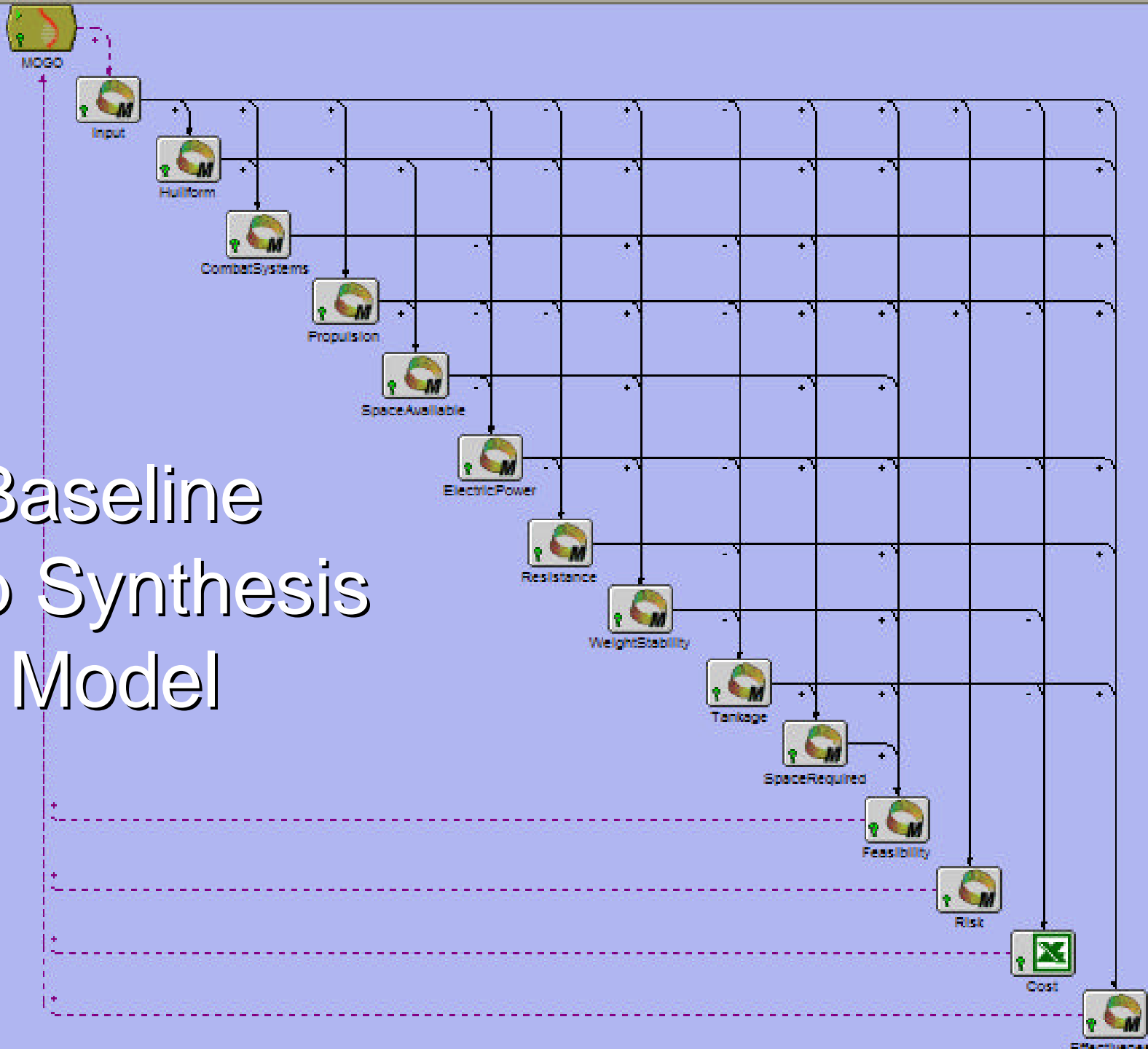

Baseline Ship Synthesis Model



MC Design Space Visualization

- Developed using Boeing's Design Explorer Technology
- Gain a better understanding of design space
 - Increase insight into the effects of key parameters
 - Develop better designs, simplify models
- Generate dataset using one of ModelCenter's trade study tools
- Access toolset from ModelCenter's Data Explorer
 - Variable Influence Profiler
 - Variable Importance Plots
 - Main Effects Plots
 - Interaction Effects Plots
 - Prediction Profiler

Add Page



2D Polar

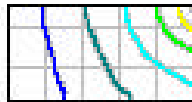

3D Surface Plot

Carpet Plot

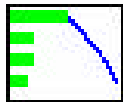
Color Grid

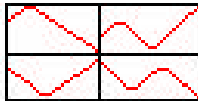

Contour Plot

Main Effects

Variable Influence
Profiler

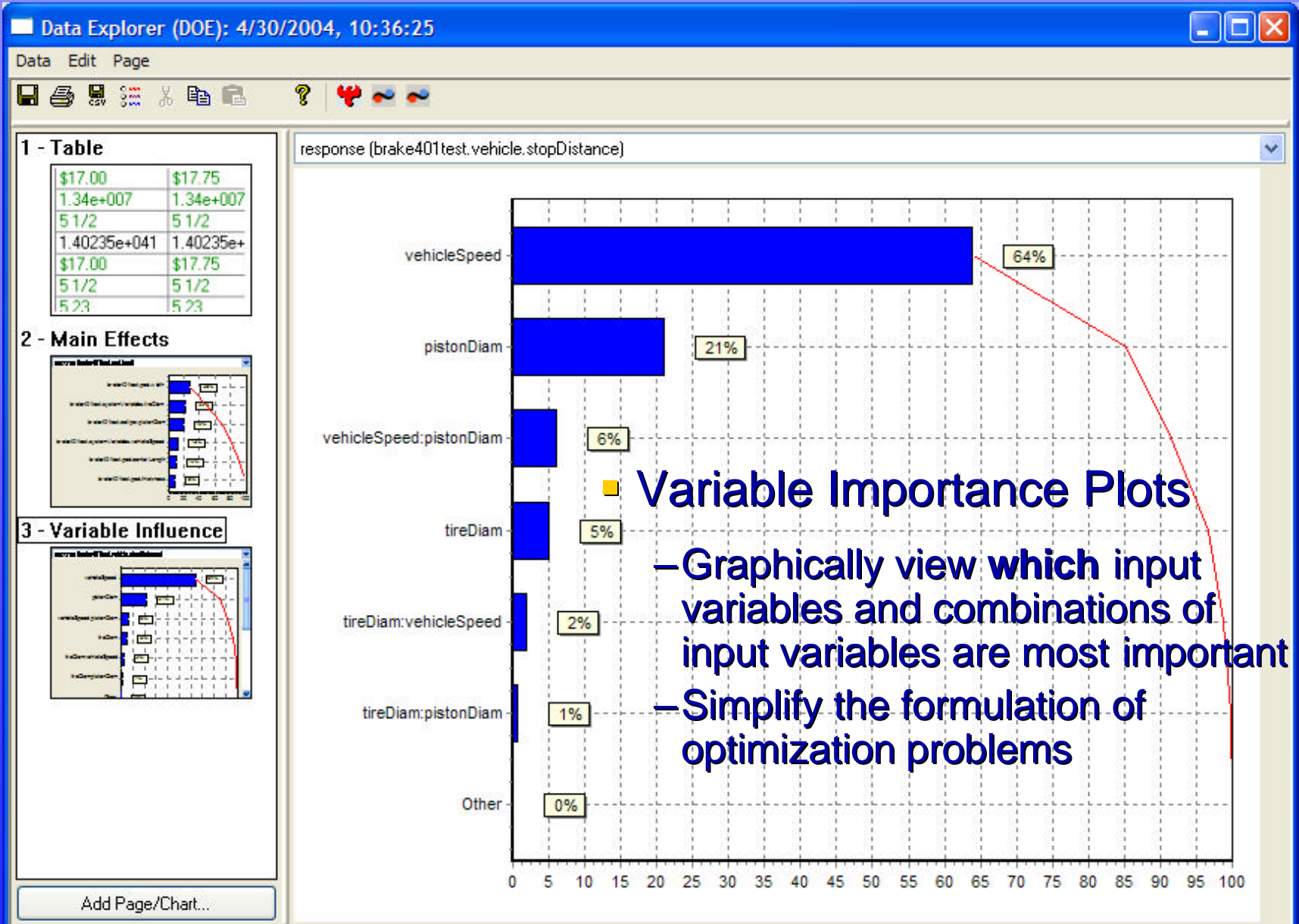

MC Design Space Visualization





MC Design Space Visualization

- Main and Interaction Effects Plots
 - Graphically view how input variables affect a selected output variable
 - Determine design trends
 - Locate regions in the design space that contain promising solutions

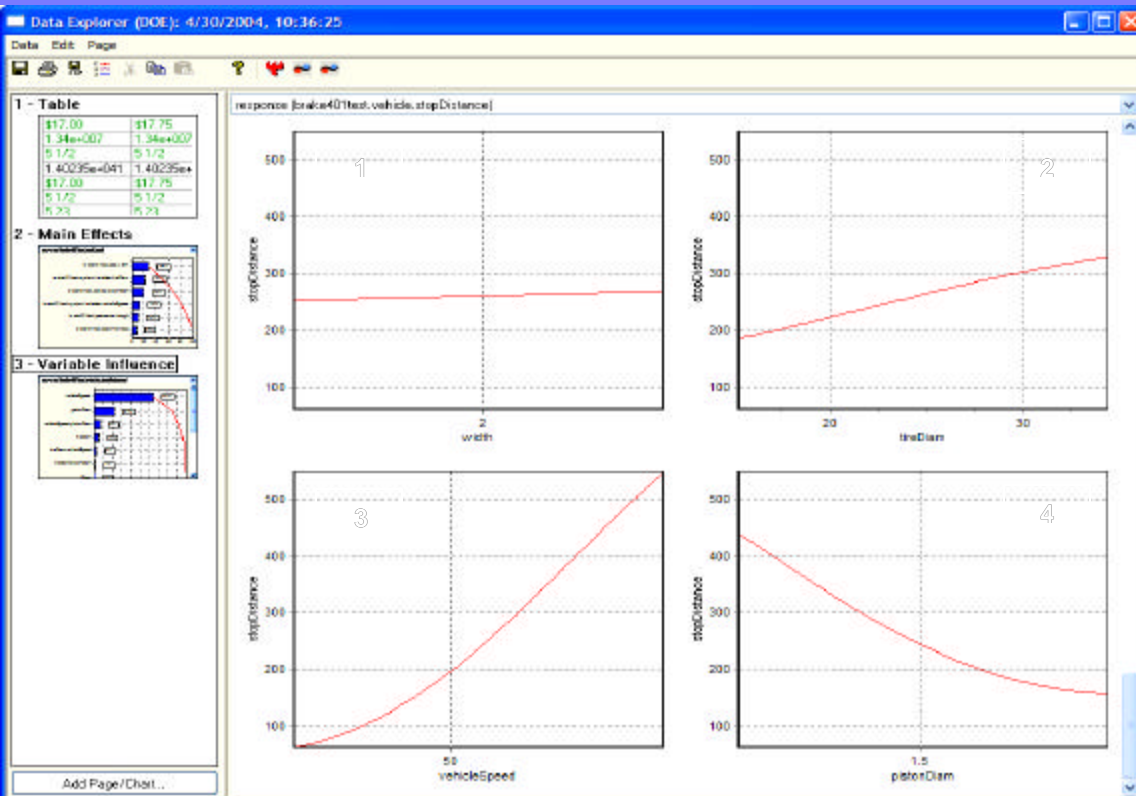

Main (single variable) Effects

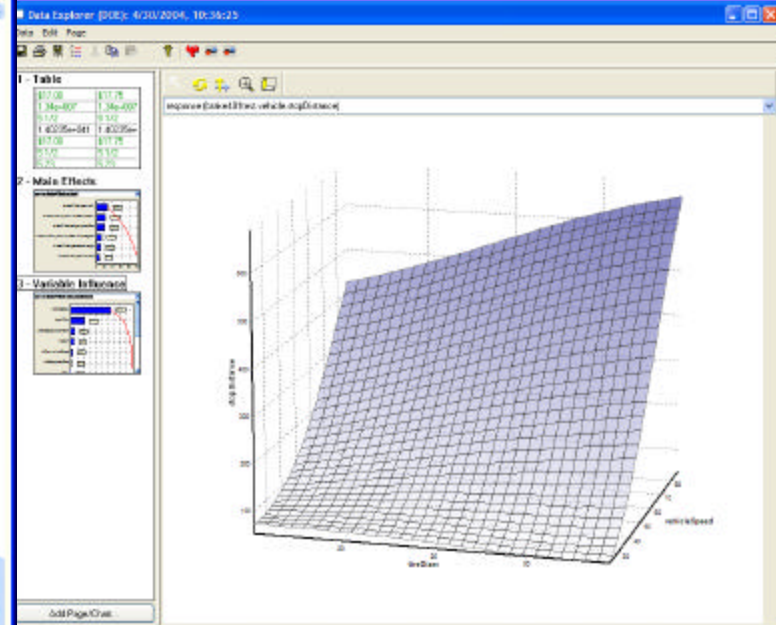

Interaction (combined variable) Effects



Evolutionary-Based Optimization

- Global optimization scheme
- Discrete and continuous design variables
- Single objective optimization
- Multi-objective optimization trade-off studies

Darwin Optimization Plug-In 1.1

Optimizer Help

Objective Definition

Objective	Value	Goal
Model Cost/Model TotalSystemCost	376000.000000	minimize
Model Scenario TotalScore	0.5183524	maximize

Design Variables

Variable	Type	Value	Start Value	Lower Bound	Upper Bound	Edit
Model Specification SensorType	discrete	High Aperture	High Aperture			
Model Specification PlatformType	discrete	Track Vehicle	Track Vehicle			
Model Defense System NumberOfPlatforms	discrete	4	4			

Single Analysis Create Super

Optimization Progress

Objective(s) Critical Margin Elapsed Time

Generations without Improvement = 0

OK Options...

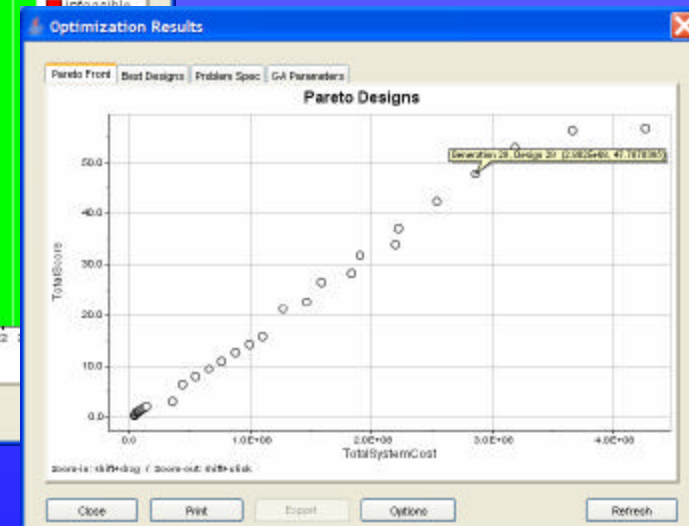
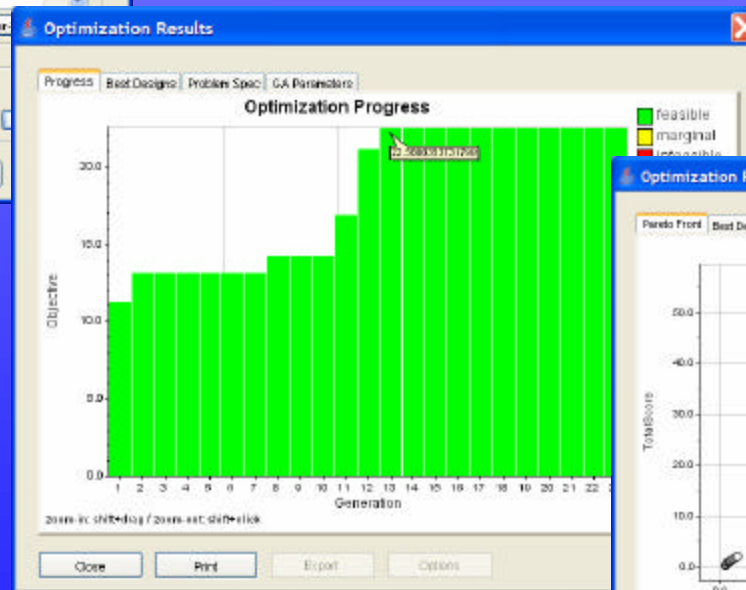



MC Design Optimization Future Releases

- **Boeing's Design Explorer Optimization Tools**
 - A unique global search optimization algorithm that intelligently uses
 - DOE, Surrogate models, Gradient-based techniques
 - Designed for computationally expensive analysis codes and noisy design spaces
 - Make critical market decisions faster
 - Evaluate numerous alternatives to identify the best design
 - Boeing evaluated 27,000 designs in the same amount of time it used to take for 25 designs

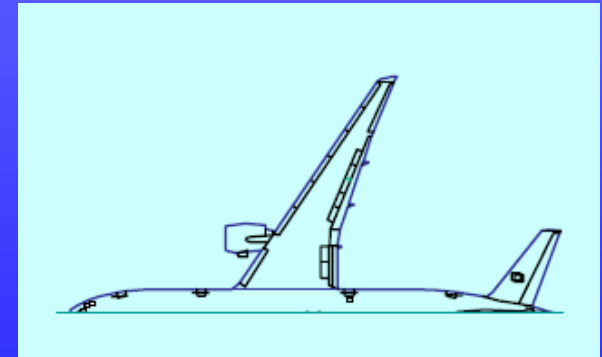



Multi-Objective Genetic Optimization (MOGO)

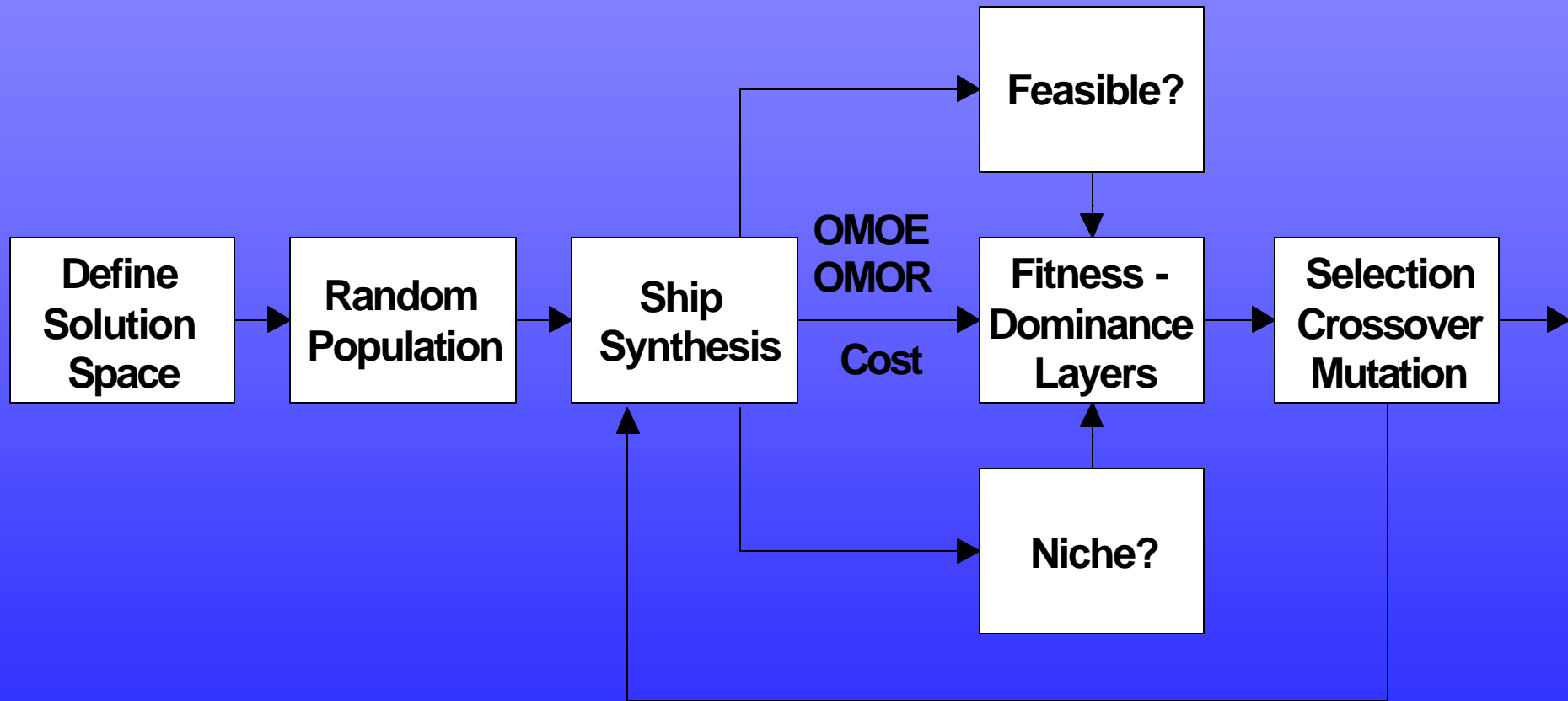



Non-Dominated Frontier (NDF)

DD21 Non-Dominated Frontier - >75% Confidence

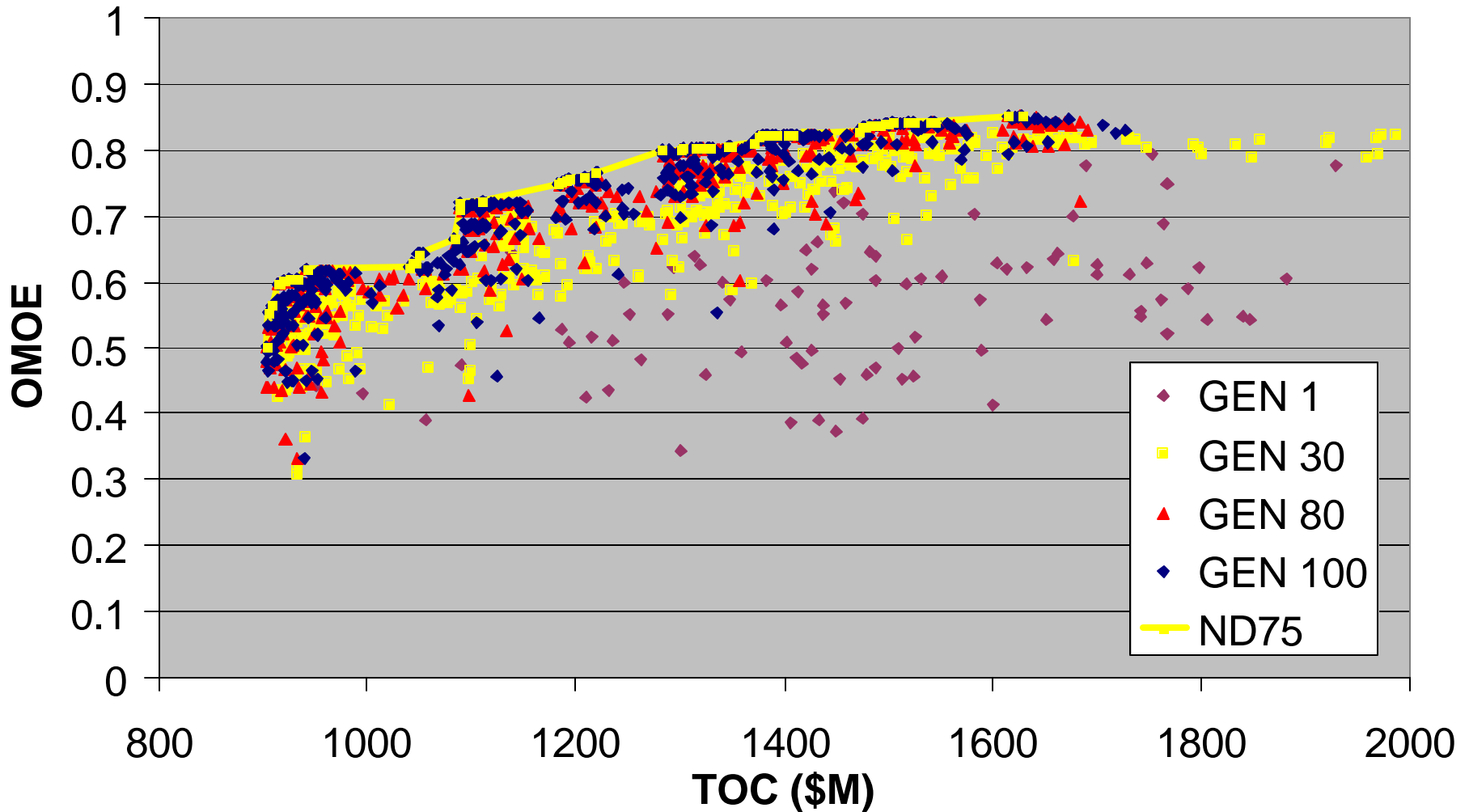



Concept Development

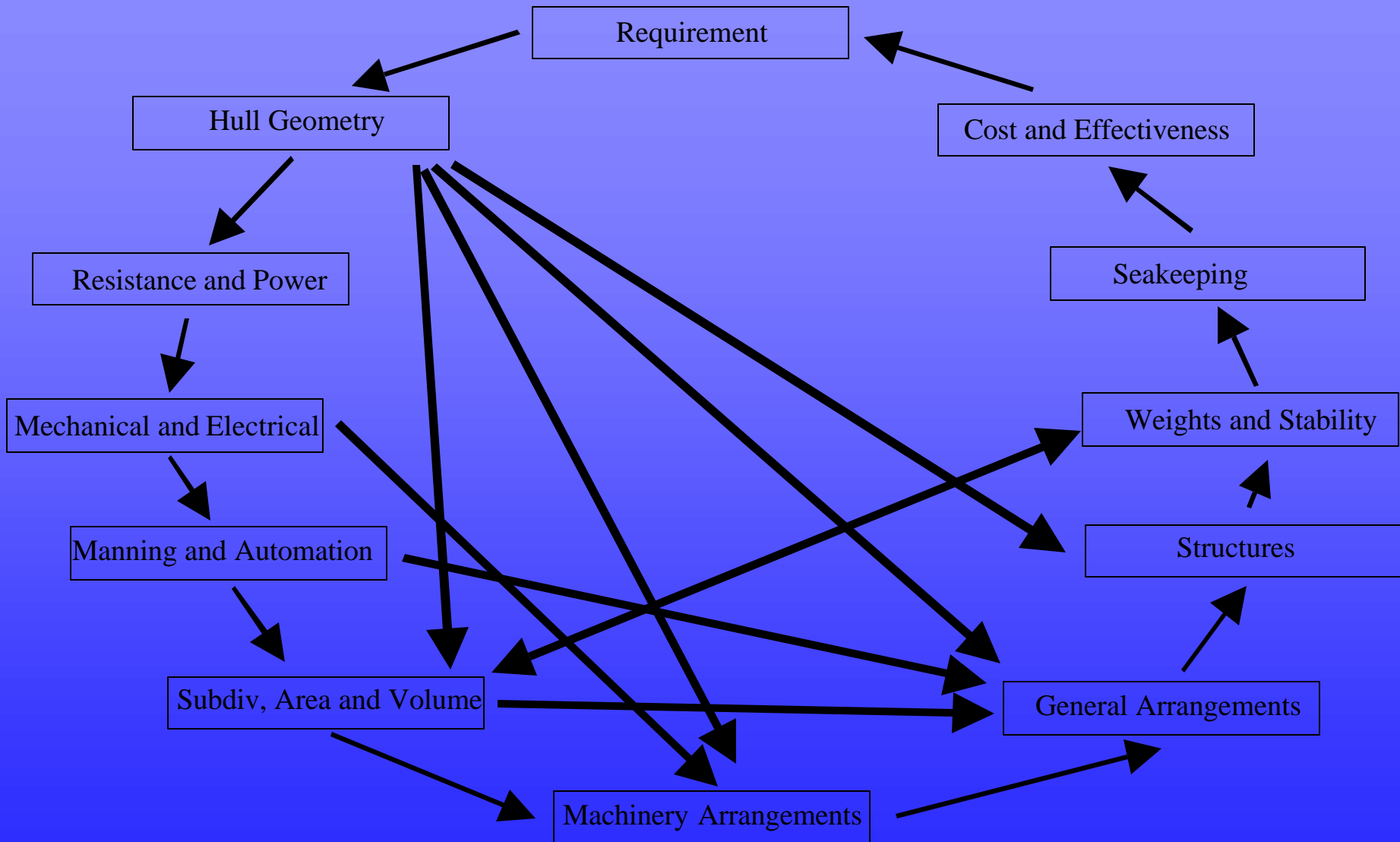



Soon

- Naval Ship Systems Engineering
- Graduate Design Projects
- Navy surface ships, submarines, return to commercial ships
- More design space exploration



Current Design-Related Projects

- Structural Optimization Module (MAESTRO)
- Vulnerability Analysis Module (LSDYNA)
- Multi-hull Resistance and Seakeeping (SWAN)
- Submarine Design
- Non-Dominated Trade-off Space
- OMOE Validation
- LHA(R) OMOE
- LHA(R) ASSET Synthesis
- Uncertainty Analysis and POS
- Submarine Synthesis Model



MAESTRO Structural Optimization

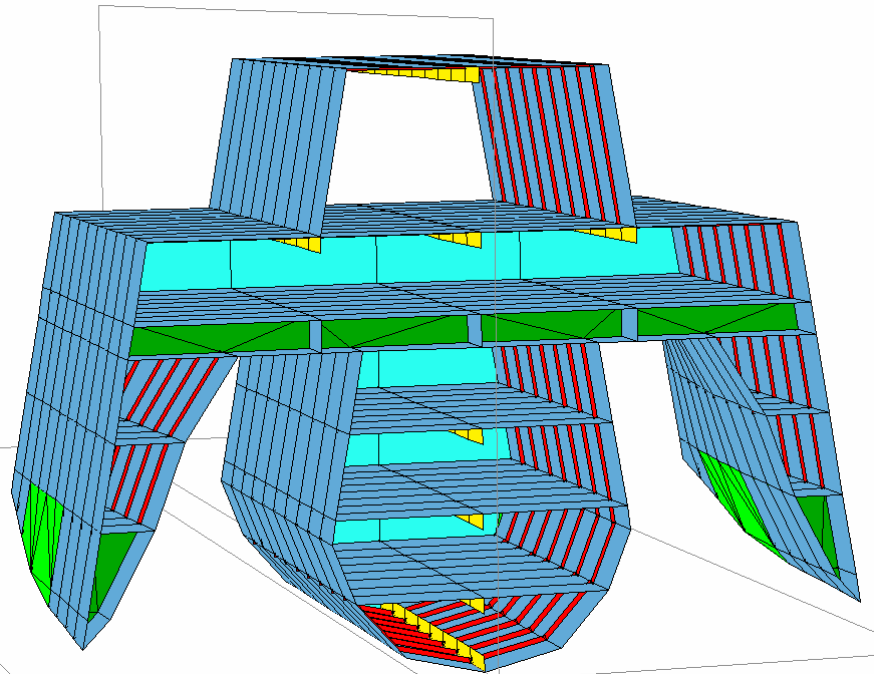
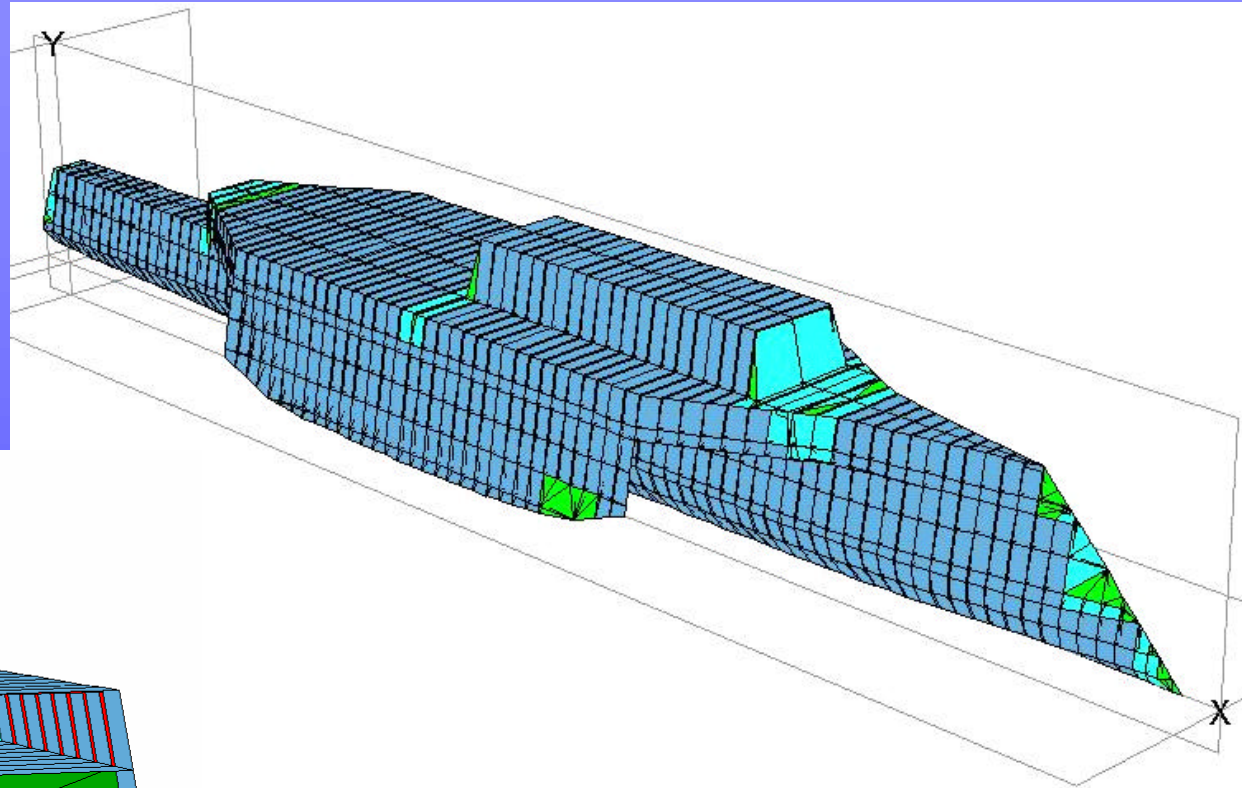

- Build baseline model using modeler
- Modify using *.dat and *.out
- Stretch y and z – move endpoints
- Stretch z - add parallel midbody
- MAESTRO optimizer
- MAESTRO weight

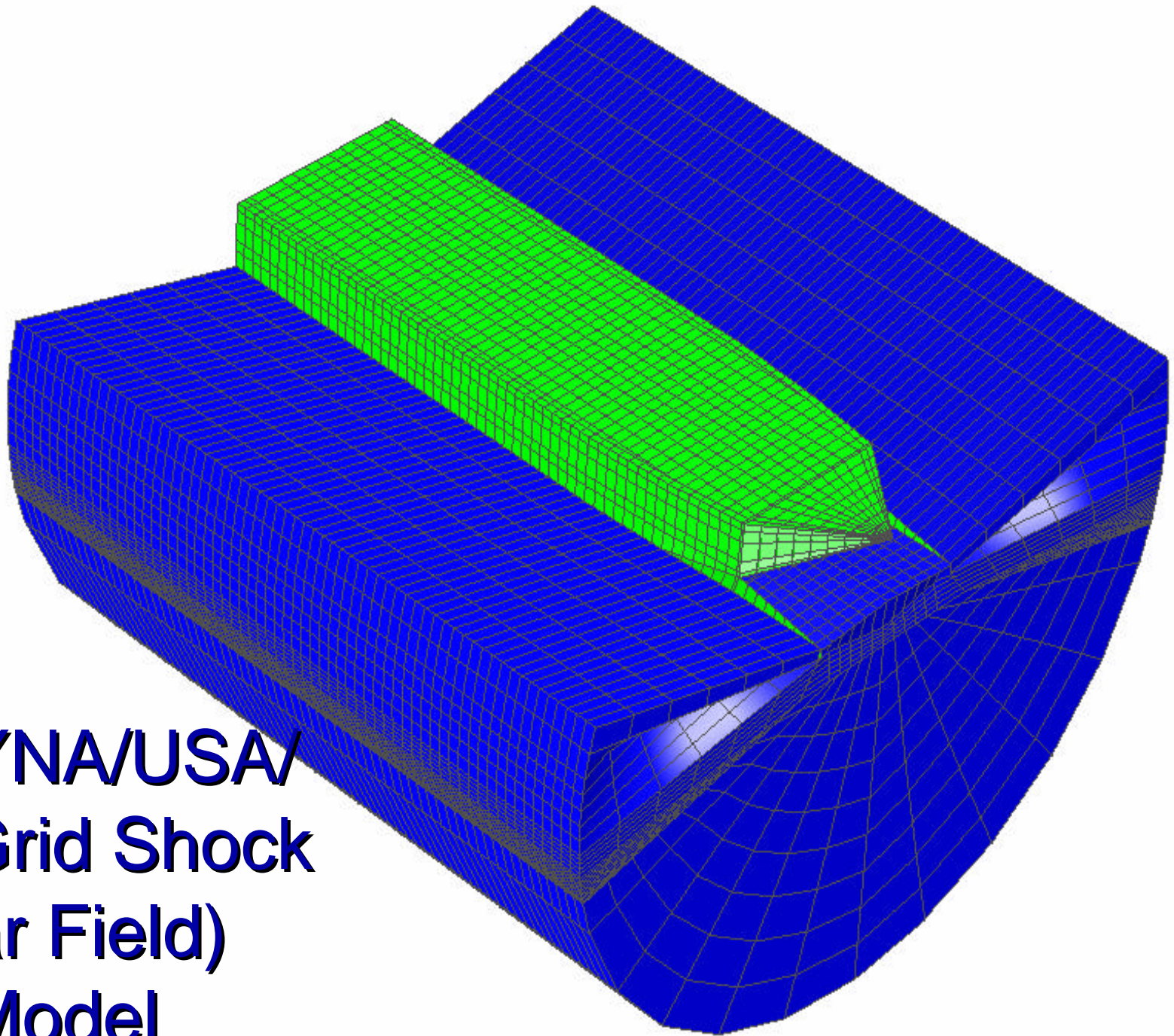

LSDYNA/USA/
TrueGrid Shock
(Far Field)
Model

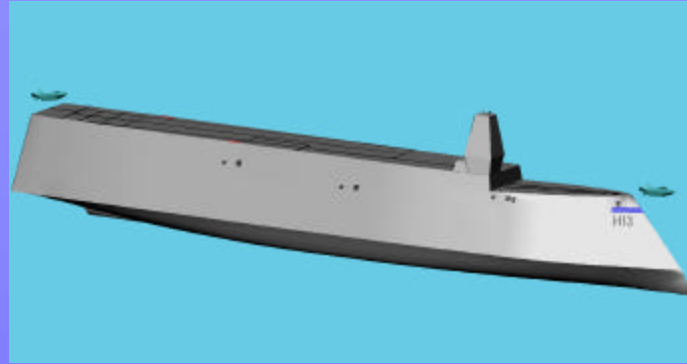

Questions?



Dr. Alan Brown
Department of Aerospace and Ocean
Engineering
email brown@aoe.vt.edu